

**LOCK & CYLINDER INSTALLATION**

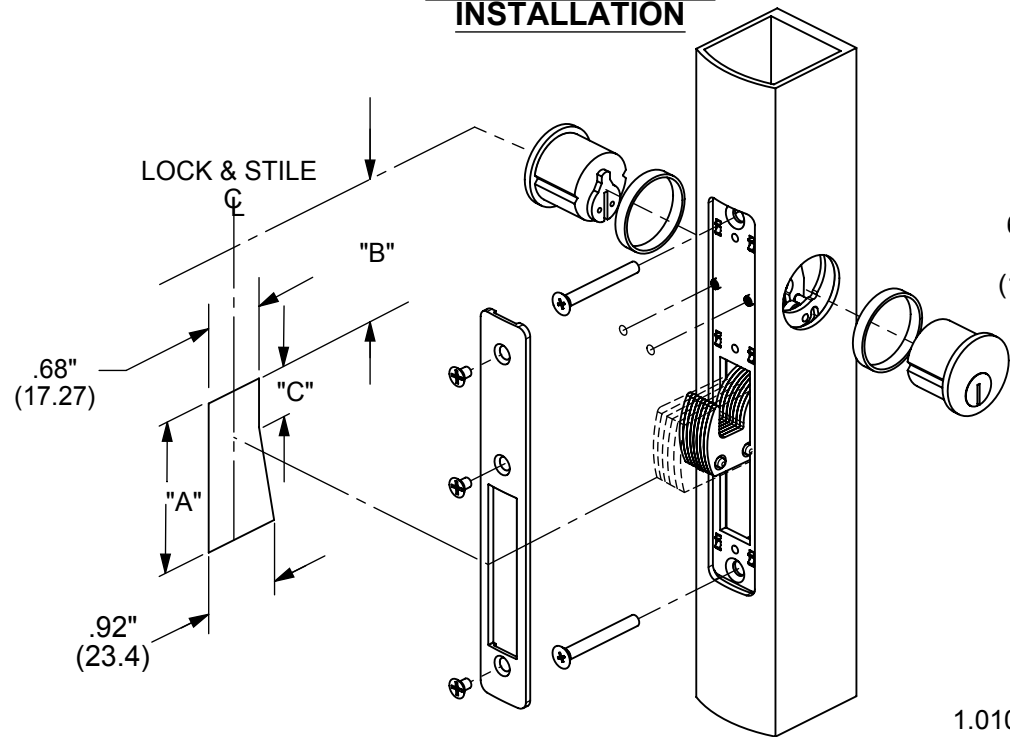

BOLT TYPE	"A"	"B"	"C"
REGULAR BOLT	3.38" (85.85)	1.38" (35.05)	1.00" (25.40)
SHORT BOLT	2.75" (69.85)	1.38" (35.05)	1.00" (25.40)
HOOK BOLT	1.94" (49.28)	2.19" (55.63)	.25" (6.55)

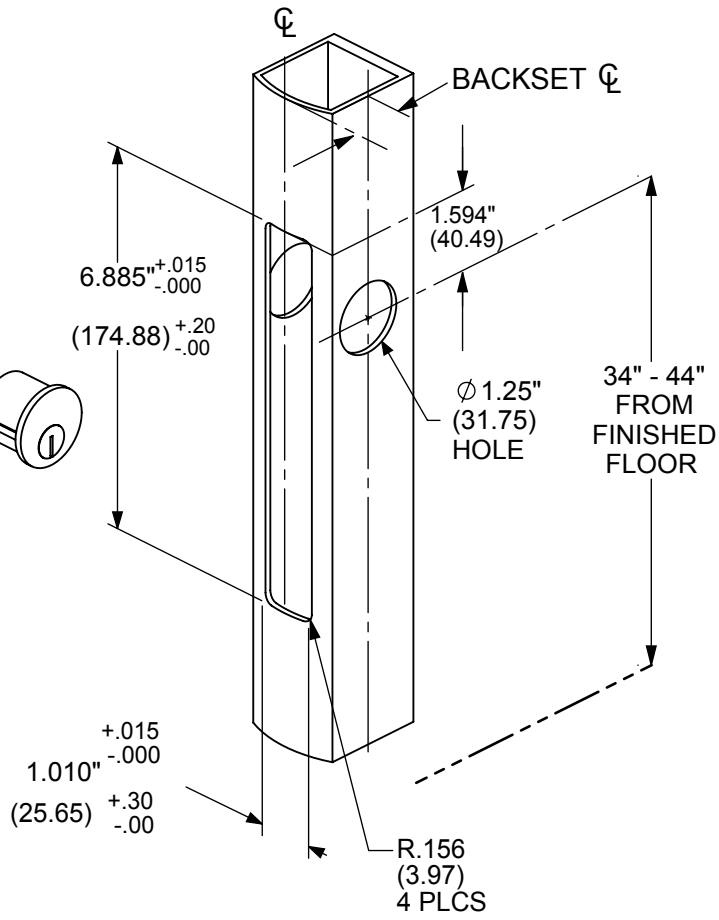

**LOCK STILE PREPARATION**

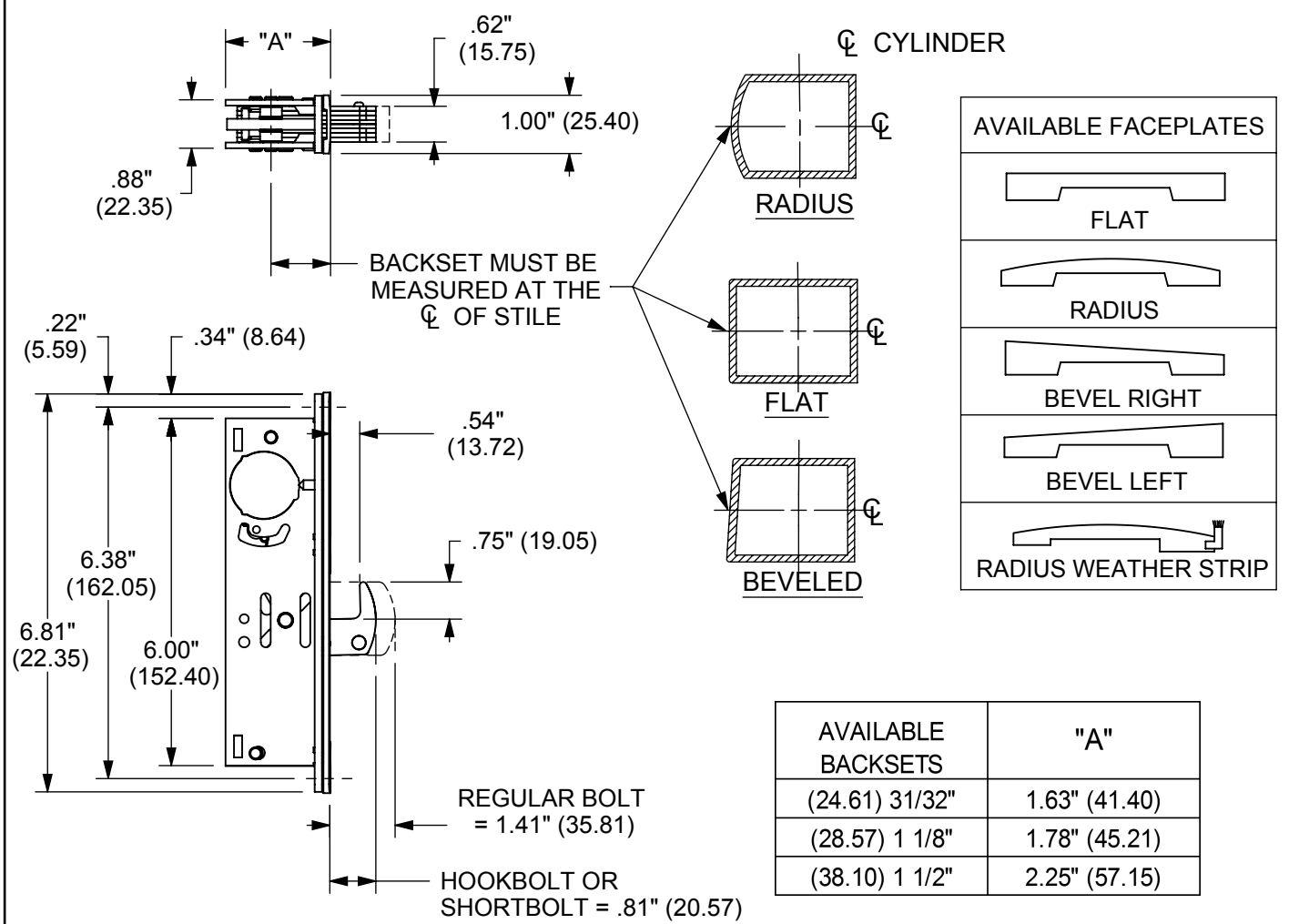

**ALTERNATE MOUNTING METHODS**

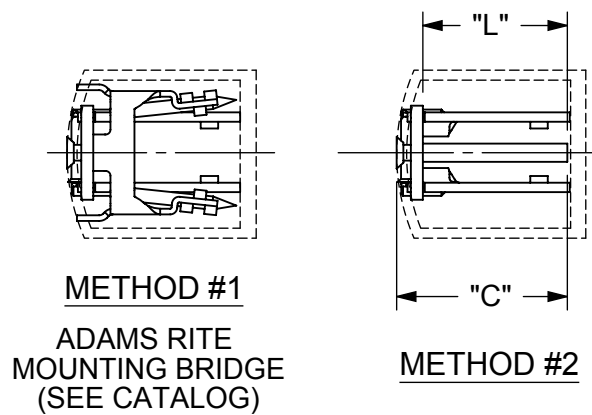

LOCK IS SECURED TO BACK WEB OF STILE BY MEANS OF TWO (2) #10 (M5) FLAT HEAD MACHINE SCREWS & TWO (2) TUBE SPACERS OF PROPER LENGTH TO POSITION LOCK. TO DETERMINE TUBE SPACER LENGTH (L) USE THE FOLLOWING FORMULA:

$$L = C - .25 \quad (6.35)$$

SCREWS WILL BE FURNISHED APPROX. 1/4" LONGER THAN THE SPACER.

**CYLINDER TRIM RING**

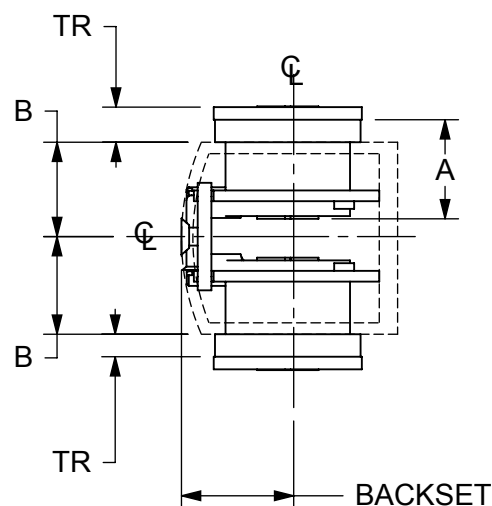

TRIM RING THICKNESS (TR) WILL VARY WITH SPECIFIC CYLINDER MAKE, NUMBER OF PINS & SPECIFIC DOOR THICKNESS. TO DETERMINE TRIM RING THICKNESS, USE THE FOLLOWING FORMULA:

$$TR = A + .125 - B \quad (3.17)$$

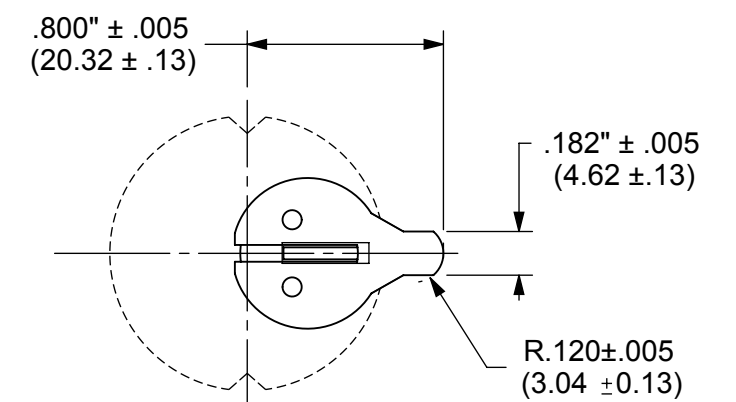

THE MS SERIES LOCKS ARE OPERABLE BY ANY STANDARD 1 5/32" DIAMETER (29.37) MORTISE CYLINDER WITH SPECIAL MS CAM DIMENSIONED AS ABOVE. CYLINDERS WITH MS CAMS CAN BE READILY OBTAINED FROM MOST CYLINDER MANUFACTURERS.