

AVAILABLE BACKSET	"A"
31/32 (24.6)	1.6 (40.6)
1 1/8 (28.6)	1.75 (44.5)

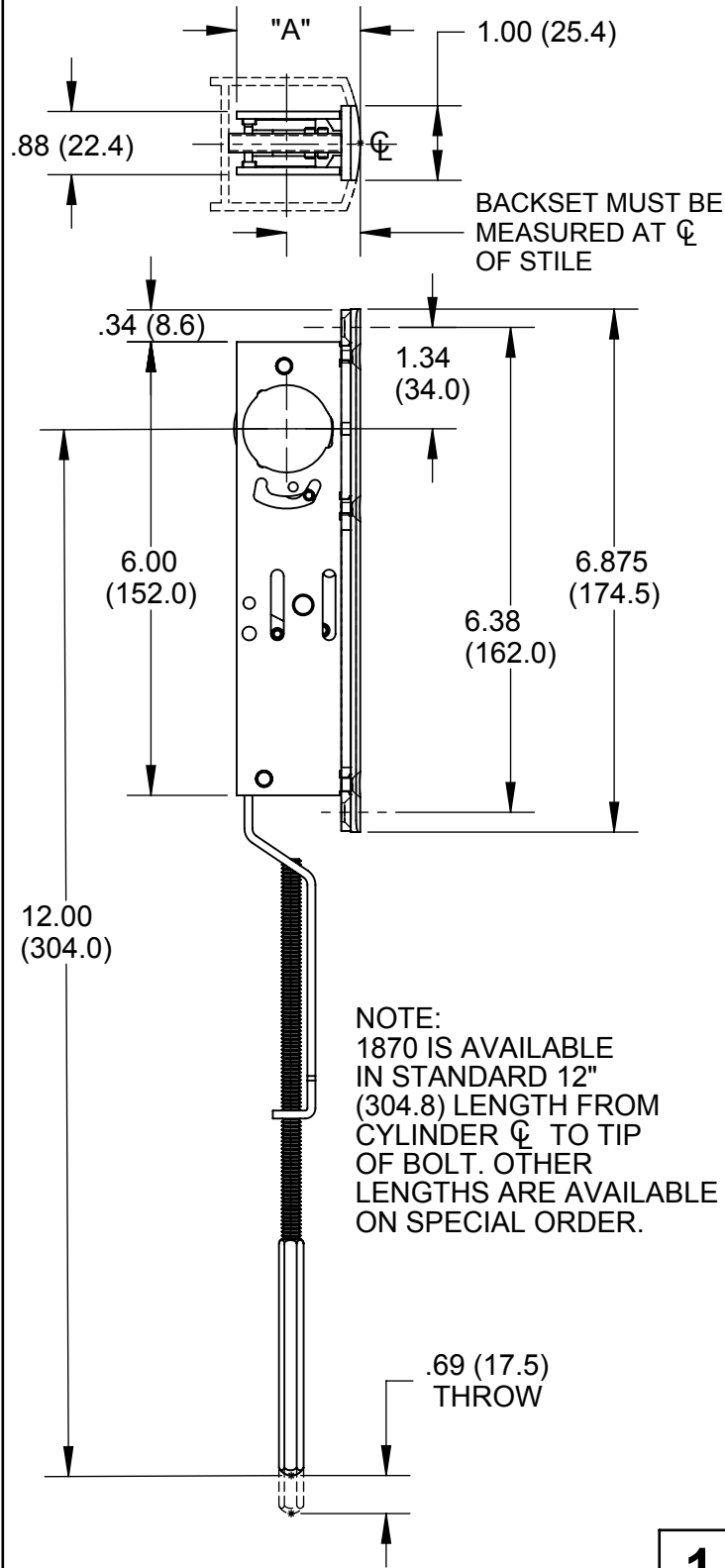

1

## INSTALLATION

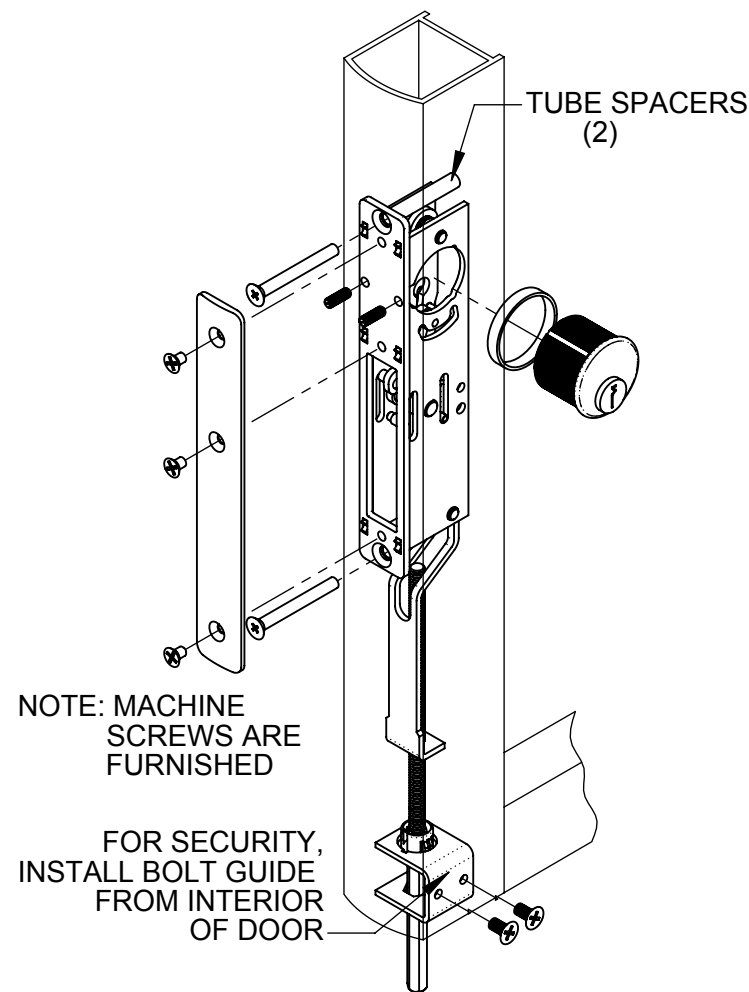

- NOTES:
1. WITH THE LOCK IN THE UNLOCKED CONDITION, SCREW THE ROD-BOLT ASSEMBLY INTO THE ACTUATOR ARM TO APPROXIMATELY 12" (305) FROM THE TIP OF THE BOLT, TO THE CENTERLINE OF THE CYLINDER OPENING. (SEE SECTION 1).
  2. INSTALL THE ASSEMBLED UNIT THRU THE CUTOUT IN THE STILE, AND SECURE WITH #10 SCREWS.
  3. AFTER ADJUSTING THE ROD-BOLT ASSEMBLY EVEN WITH THE BOTTOM OF THE DOOR STILE, INSTALL THE BOLT GUIDE USING #10 SCREWS FURNISHED. FOR ANY FUTURE ADJUSTMENTS, THE BOLT GUIDE MUST BE REMOVED BEFORE THE ROD-BOLT ASSEMBLY CAN BE ROTATED.
  4. INSTALL RADIUS FACEPLATE WITH SCREWS FURNISHED.

2

## STILE PREPARATION

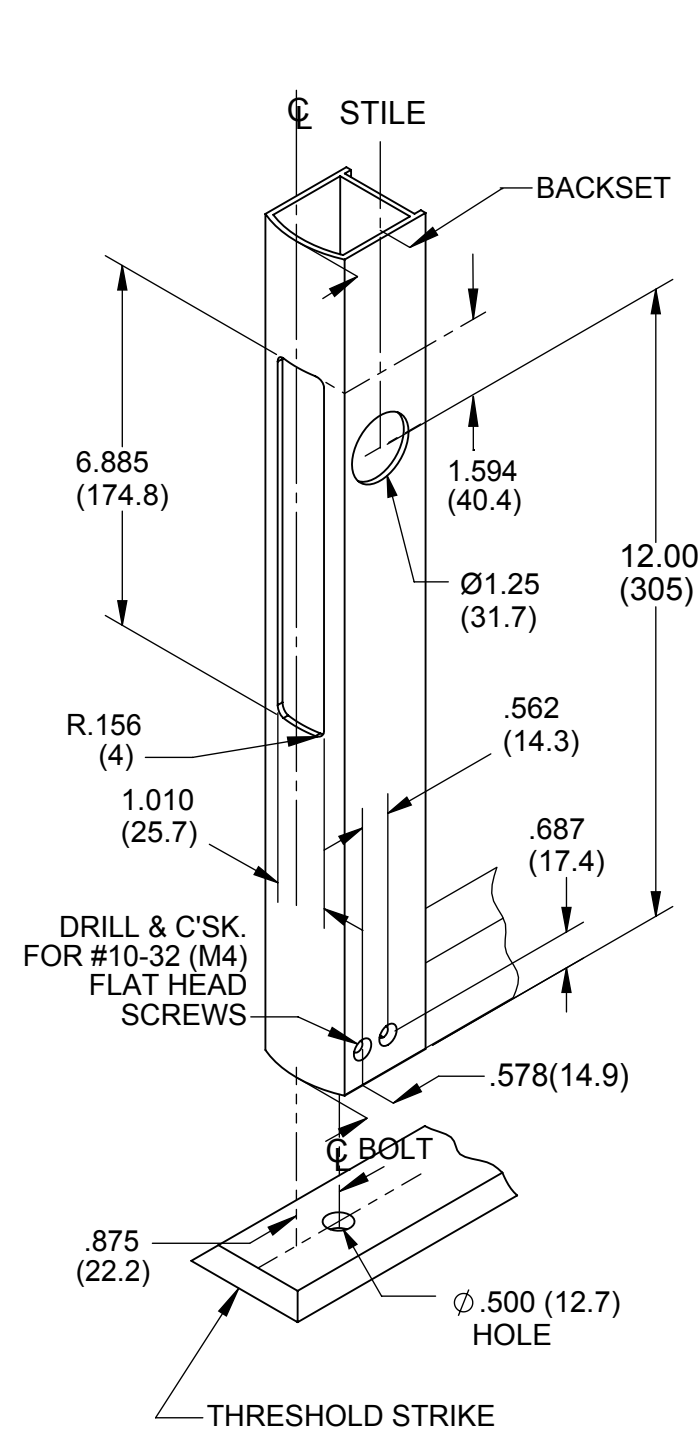

3

1870 SERIES LOCKS ARE OPERABLE BY ANY STANDARD 1 5/32" DIAMETER (29.4) MORTISE CYLINDER WITH SPECIAL M.S. CAM DIMENSIONED AS SHOWN. CYLINDERS WITH M.S. CAMS CAN BE READILY OBTAINED FROM MOST CYLINDER MANUFACTURERS.

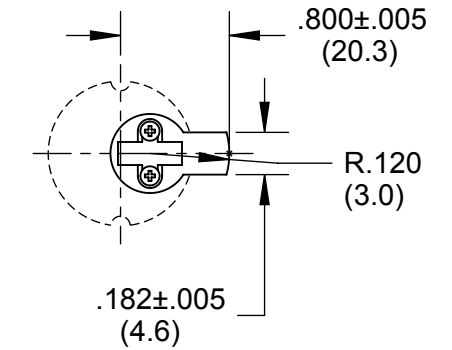

6

## CYLINDER TRIM RING

TRIM RING THICKNESS (TR) WILL VARY WITH SPECIFIC CYLINDER MAKE. NUMBER OF PINS & STILE THICKNESS TO DETERMINE TRIM RING THICKNESS. USE THE FOLLOWING FORMULA.

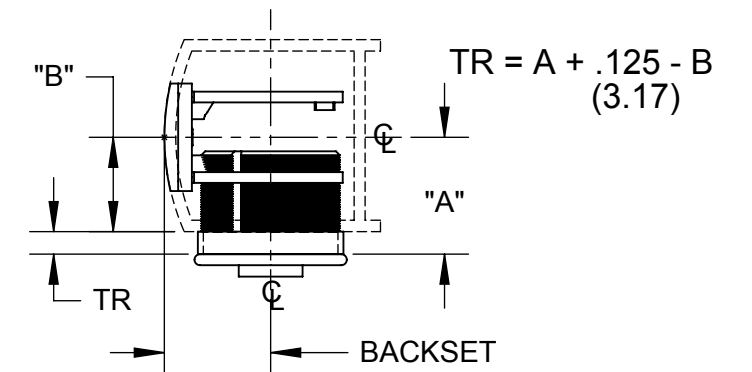

5

## MOUNTING METHOD

LOCK IS SECURED TO BACK WEB OF STILE BY MEANS OF TWO (2) #10 FLAT HEAD MACHINE SCREWS AND TUBE SPACERS OF PROPER LENGTH TO POSITION LOCK.

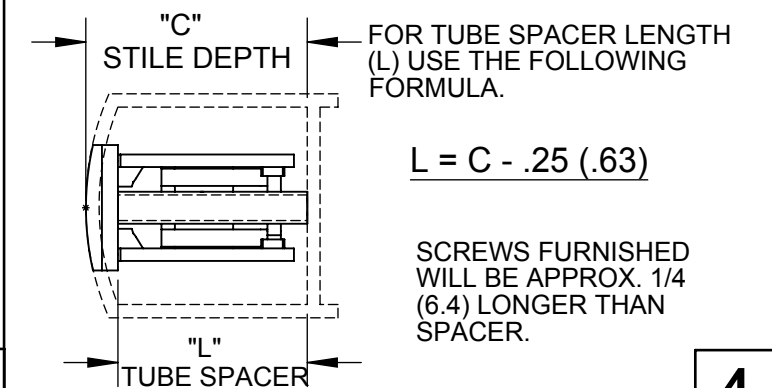

4