



# GL1

## 2000lbs Holding Force Gate Lock

### Electromechanical Gate Solution Offers One Ton of Holding Power

The heavy duty GL1 Electromechanical Gate Lock provides weather-resistant access control for a wide range of gate applications. The GL1 provides 2000lbs of holding force for electrical and manually operated indoor or outdoor gates where preload is a concern. Ideal for swinging or sliding vehicle, pedestrian, or stock gate access control.

#### PRODUCT FEATURES

- 2000lbs holding force
- Operates under preload up to 100lbs
- Automatic dual voltage - no field adjustment required
- Accepts a standard mortise cylinder with Adams Rite MS cam for manual key override (not included, see spacer guide below)
- Self-aligning receiver (+/- 1/2" horizontally) helps compensate for gate misalignment and sag
- Tamper resistant cast housing
- Optional latch status monitor
- Surface mount
- MagnaCare Lifetime Replacement No Fault Warranty

#### SPECIFICATIONS

- Patent: 8,047,582
- Holding Force:**  
2000lbs [907kg]
- Dimensions:**  
2-3/4"L x 7-1/4"W x 3-1/4"D
- Electrical:**  
12 Volts Initial (Peak): (~1.0 sec.) @ 870mA - Reduced: 290mA Power Consumption: 3.5 Watts  
24 Volts Initial (Peak): (~1.0 sec.) @ 720mA - Reduced: 170mA Power Consumption: 4.1 Watts
- Operating temperature:**  
-58 to +167F [-50 to +75C]  
Indoor or outdoor use
- Shipping Weight:**  
6lbs [2.72kg]
- Finishes:**  
Black Finish

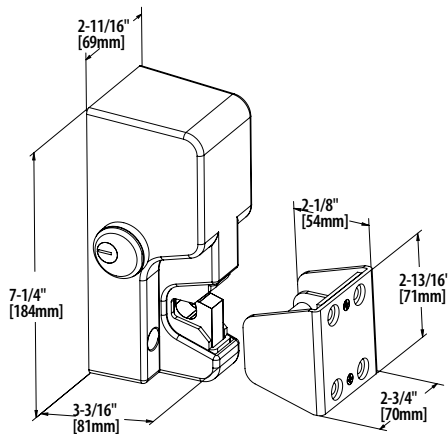

#### Mortise Spacer Guide

Cylinder Length	Spacer Required
1"	1/4"
1-1/8"	3/8"
1-1/4"	1/2"



#### MODELS

Model	Part #   Description
GL1-FL	Gate Lock, 12/24VDC, Standard Fail Locked
GL1-FS	Gate Lock, 12/24VDC, Standard Fail Safe
GL1-FLM	Gate Lock, 12/24VDC, Monitored Fail Locked
GL1-FSM	Gate Lock, 12/24VDC, Monitored Fail Safe
GMC	Gate Lock Mortise Cylinder (FL Models Only)

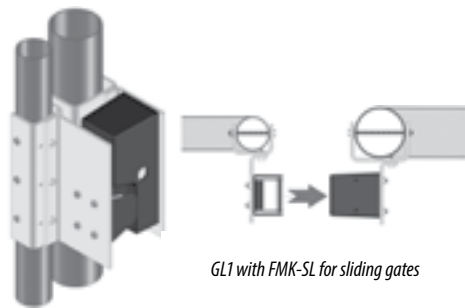

GL1 with FMK-SL for sliding gates

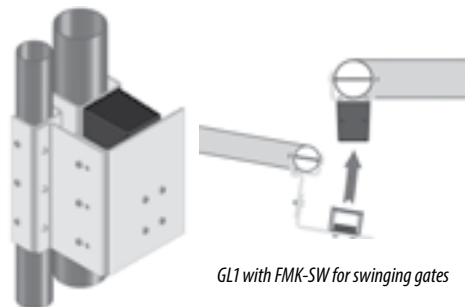

GL1 with FMK-SW for swinging gates



DUAL VOLTAGE

