

High Security Closers Series

APPLICATIONS

- For any concealed or surface mounted installation subject to potential abuse or vandalism.
- For correctional, aluminum, hollow metal, or wood doors and frames.
- Can be used with hinge or pivot mounted door.
- Adapter plates and other installation accessories available for unusual conditions.

FEATURES COMMON TO HIGH SECURITY CLOSERS

- Each closer is a vandal resistant design for a specific mounting; hinge side, parallel arm, stop face, or concealed.
- All high security closers are based on a cylinder certified to exceed 10,000,000 cycles in independent testing.
- Handed for right or left swinging doors.
- Closers to meet ADA reduced opening force requirements.
- All closers furnished with TORX tamper resistant machine screws.
- All surface mount closers include a heavy gauge steel cover with four attachment points.
- All closer adjustments are protected when installation is complete.
- All track closers use a jam resistant track and tamper resistant arm/roller assembly.
- Adjustable hydraulic backcheck cushions opening swing prior to 90°.
- Advanced variable backcheck (AVB) is available on all high security closers.
- Separate regulation of general closing speed and latching speed.

DESIGN ASSISTANCE

LCN has been providing reliable solutions to unique door control problems since 1925. Design and specification assistance are only a phone call away. Contact LCN for assistance or technical information at **877-671-7011** or FAX **800-248-1460 (order entry)**, Fax **815-879-1495** for Technical Support.

WARRANTY

High Security Series closers carry a 15 year limited warranty, except for the 2210DPS Series closer that carries a 2 year limited warranty. See General Information Section for complete warranty details.

MATERIALS

- High strength **cast iron** cylinder.
- **Forged steel** main arms and forearms.
- One piece **forged steel** piston.
- LCN's all weather "**Liquid X**" fluid performs to temperature ranges from 120°F (49°C) to -30°F (-35°C) without any seasonal adjustment.
- **High efficiency, full complement**, low friction bearings.
- **Double heat treated** pinions.
- Tamper resistant regulating screws.
- Full rack and pinion hydraulic action.
- Quiet, low friction track and roller combination for all single lever arm closers.

FINISHES

- Available in six standard or a wide selection of optional custom powder coat finishes to blend with door and frame.
- LCN's powder coat finishes surpass 100 hours of salt spray which is over four times the ANSI standard for corrosion resistance.
- For installations where a higher level of corrosive resistance is required,

LCN offers an optional special rust inhibiting (SRI) pre-treatment. Closers that combine the exclusive LCN powder coat finish and the SRI pre-treatment exceed the ANSI standard for corrosion resistance even further.

- Plated finishes are available as an option to accent door and frame.

LISTINGS & APPROVALS

UL listed for self-closing doors without hold-open under "SWINGING DOOR CLOSERS" (GVEV) file R 1943.

Tested and certified under ANSI Standard A 156.4. Consult factory for details.

Consult factory for other listings such as; ULC, California State Fire Marshal, Bureau of Standards and Appeals.

POSITIVE PRESSURE

LCN closers have been certified for three hours by UL to be in compliance with UL 10 C. Contact LCN for specific details on door closer fire ratings.

FASTENERS

TORX MACHINE SCREW (TORX) pack contains tamper resistant machine screws to install the closer. Thru Bolts for TORX machine screws are available for all high security closers, except 2210 series.

LCN thru bolts (TB) can be installed on 1-3/4" thick doors with the 1/4-20 TORX screws supplied with the closer. Optional sizes are available for 1-5/8" or 1-3/8" door thicknesses, but this must be specified when ordering.

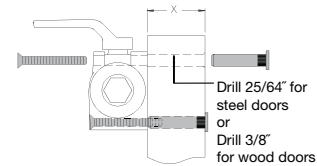

Note 1: For Thru Bolts, specify door thickness if other than 1-3/4" (44mm).

Special driver bits are required for installation or removal of TORX machine screws with a security pin as supplied with LCN High Security closers. All bits fit a 1/4" hex drive socket. For 1/4-20 screws use T-27, for #12 machine screws use T-25, for 10# machine screws use T20, for #8 (and undercut #10) machine screws use T15, and for #6 machine screws use T10. The specific bits required for installation are listed on the "HOW TO ORDER" page for each closer. Sold separately.

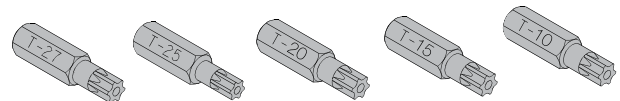

FASTENERS

TORX MACHINE SCREW (TORX) pack contains tamper resistant machine screws to install the closer. Thru Bolts for TORX machine screws are available for all high security closers, except 2210 series.

SPECIFICATIONS

Refer to "SPECIFICATIONS" section for suggested architectural specifications.

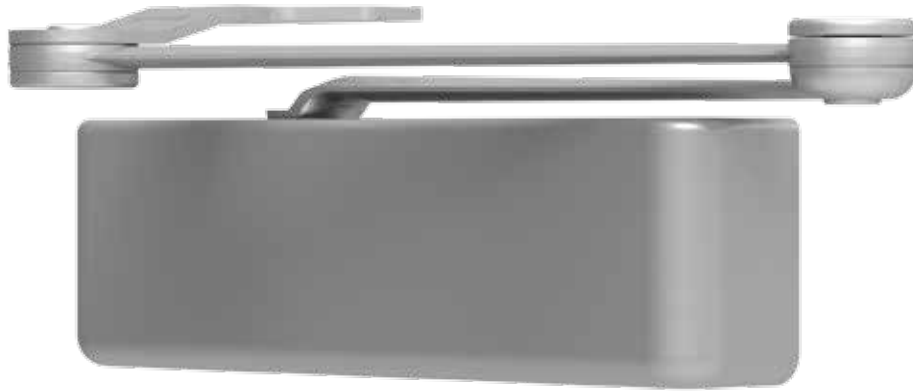

The 4210 SMOOTHEE® Series is a heavy duty, high security closer with special components to minimize tampering and vandalism. Forged steel parallel arms and heavy gauge metal security covers are designed for correctional, vandal prone, institutional and other high traffic applications. The closer has passed 10 million cycles in independent testing. A choice of finishes and cylinder functions meet correctional and vandal resistant requirements.

Certifications	Grade 1 - ANSI A156.4, UL 10C, ADA*, 100 Hour Salt Spray, Meets BAA - Buy American Act <i>*4211 cylinder meets ADA</i>	Cover	Metal Security
Body Construction	<ul style="list-style-type: none"> Cast Iron Body Full Complement Bearing 1-1/2" Diameter Piston 11/16" Diameter Double Heat Treated Pinion Journal 	Fasteners	TORX machine screw pack
Fluid	All Weather Fluid	Mounting	Parallel (Push Side)
Handing	Handed	Arms	Extra duty, non hold-open
Size	<ul style="list-style-type: none"> Adjustable Exterior and, Vestibule, Size 3-5 or size 6 Adjustable, Interior, Size 2-5; or size 6 	Finishes/Colors/Powder Coat	<ul style="list-style-type: none"> Aluminum (689) Statuary Bronze (690) Light Bronze (691) Black (693) Dark Bronze (695) Brass (696) Custom colors optional
Warranty	15 years		<ul style="list-style-type: none"> Optional SRI primer - powder coat only Optional plated finishes (cover only)

Special Templates

Customized installation templates or products may be available to solve unusual applications. Contact LCN Product Support for assistance.

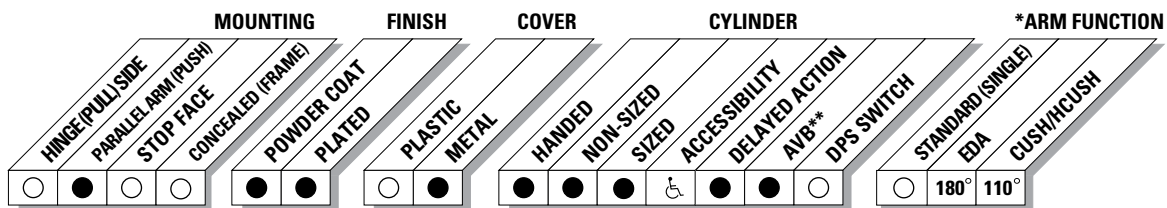

● AVAILABLE
○ NOT AVAILABLE

♿ Closer available with less than 5.0 lbs. opening force on 36" door.
* Maximum opening with standard template. See individual closer series for degrees of opening per installation.
** Advanced Variable Backcheck.

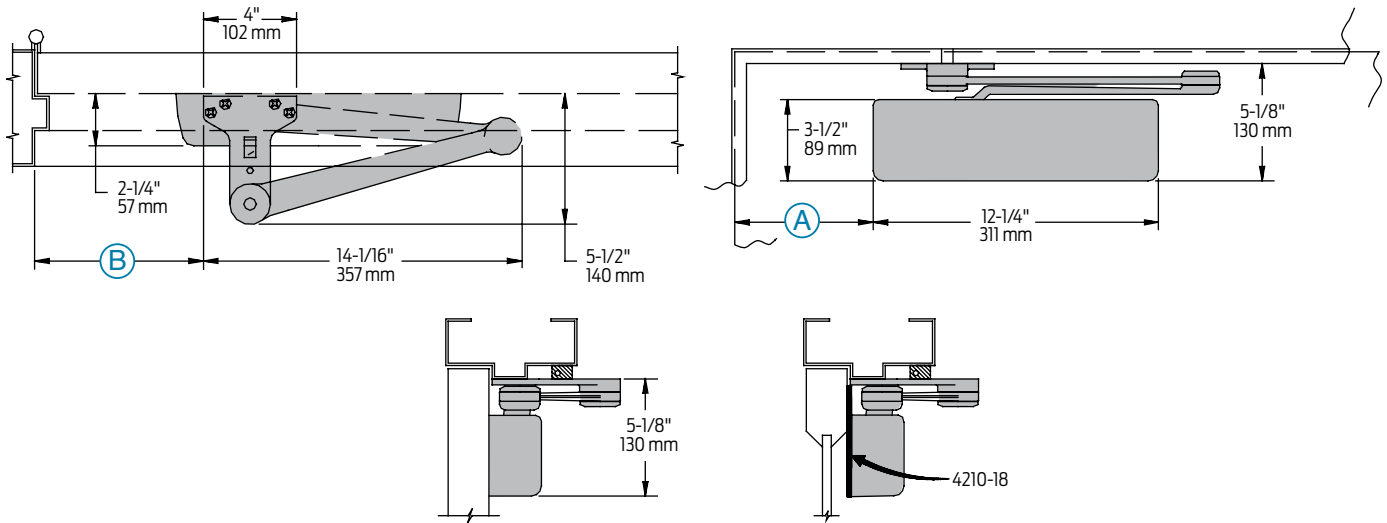

Butt Hinges	Should not exceed 5" (127 mm) in width	
Auxiliary Stop	Recommended where the door cannot swing 180° or where CUSH arms not used	
Clearance	For EDA or CUSH is 5-1/2" (140 mm) from push side of door	
Top Rail	Less than 5-1/8" (130 mm) measured from stop, requires PLATE 4210-18. Plate requires 2" (51 mm) minimum top rail	
Stop Width	2-3/4" (70 mm) recommended. Less than 1" (25mm), consult factory	
Delay Action	<ul style="list-style-type: none"> ■ Add suffix "DEL" to selected cylinder (eg. 4211DEL) ■ Not available with 4215 or 4216 cylinder ■ Delays closing from maximum opening to approximately 70° ■ Delays time adjustable up to approximately 1 minute 	
Advanced Variable Backcheck	<ul style="list-style-type: none"> ■ Cylinder starts backcheck at approximately 45° instead of the normal 75° ■ Add suffix "AVB" to selected cylinder (eg. 4211 AVB) 	
Maximum opening	EDA arm can be templated for	CUSH arm can be templated for maximum opening at
	100°: A = 5-15/16" (151 mm) B = 7-1/4" (184 mm)	85°: A = 8-5/16" (211 mm) B = 9-5/8" (244 mm)
	140°: A = 4-7/16" (113 mm) B = 5-3/4" (146 mm)	90°: A = 7-11/16" (195 mm) B = 9" (229 mm)
	180°: A = 2-15/16" (75 mm) B = 4-1/4" (108 mm)	100°: A = 6-7/16" (164 mm) B = 7-3/4" (197 mm)
		110°: 5-9/16" (141 mm) B = 6-7/8" (175 mm)

Hold-open point at maximum opening with H-CUSH arm.

Options	<ul style="list-style-type: none"> ■ Delayed Action or Advanced Variable Backcheck cylinder.
----------------	---

Cylinder

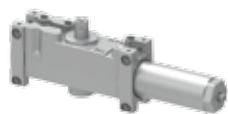

4211(6)-3071
Cylinder Assembly

- Handed
- Cast iron
- Standard

Cover



4210-72MC
Metal Security Cover

- Handed
- Four point mounting for extra security
- Closer adjustments not accessible with cover installed
- Standard

Arms



4210-3077EDA
Extra Duty Arm

- Non-handed
- Parallel arm features solid forged steel main arm and forearm for potentially abusive installations
- Double slab arm/pinion attachment for maximum strength



4210-3077CNS
Cush-N-Stop® (CUSH) Arm

- Non-handed
- Parallel arm features solid forged steel main arm and forearm with built-in stop in soffit shoe
- Double slab arm/pinion attachment for maximum strength



4210-3049CNS
HCUSH Arm

- Non-handed
- Parallel arm provides hold-open function with templated stop/hold-open points
- Handle controls hold-open function with thumb turn
- HCUSH arm not available with 4216 cylinder
- Double slab arm/pinion attachment for maximum strength

Installation Accessories



4210-18, 4210-18CUSH
Plate

- Required for push side mount where top rail is less than 5-1/8" (130 mm), measured from the stop
- Requires 2" (51 mm) minimum top rail measured from the stop.
- Also used with CUSH arm installations



4210-30
CUSH Shoe Support

- Provides anchorage for fifth screw used with CUSH arms where reveal is less than 3-1/16" (78mm)



4210-61
Blade Stop Spacer

- Lowers parallel arm shoe to clear 1/2" (13 mm) blade stop



4210-419
PA Flush Panel Adapter

- Provides horizontal mounting surface for EDA or CUSH shoe on single rabbetted or flush frame

How-to-order 4210 Series

Select cylinder size

- 4211 (adjustable from size 1 to 5)
- 4216 (DEL or HCUSH arm not available)

Select hand

- RH
- LH

Specify finish

- Standard Powder Coat _____
Aluminum, Dark Bronze, Statuary, Light Bronze, Black, Brass

Closer will be shipped with:

- Standard cylinder
- Security cover
- Standard security arm
- TORX machine screw pack, unless options listed below are selected.

NOTE: Installation of this closer requires T-27 and T-25 driver bits for TORX machine screws with a security pin. Sold separately.

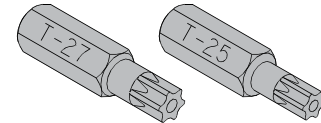

Closer options

Cylinder

- Delayed Action (DEL)
- Advanced Variable Backcheck (AVB)

Finishes

- Custom Powder Coat (RAL) _____
- Plated Finish, US _____ (cover only)
- SRI primer (excludes DPS) (use with powder coat finishes only)

Arms

- Cush-N-Stop arm (CUSH)
- HCush-N-Stop arm (HCUSH)

Screw pack

- TB* and TORX Machine Screw (TBTRX)
*Specify door thickness if other than 1-3/4".

Installation accessories

- PLATE, 4210-18
- PLATE, 4210-18CUSH

Special template

- ST- _____

Table of sizes

- Select closer based on width of door
- The spring power of non-sized 4211 cylinder is adjustable from size 1 through size 5 and is shipped set to size 3
- Sized 4210 Series cylinder available in size 6
- Delayed action not available with 4216 cylinder

Exterior (and Vestibule) door width

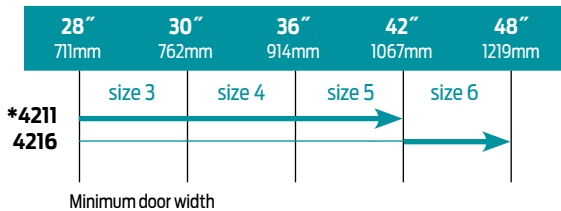

Interior door width

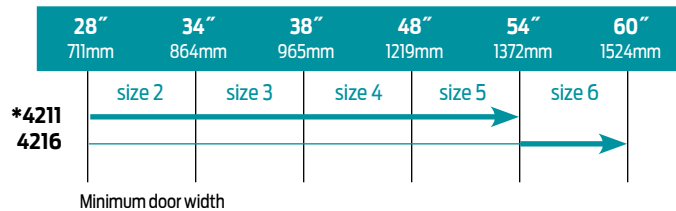

→ Indicates recommended range of door width for closer size. * Adjustable Size 1 thru 5

Reduced opening force 4210 Series closers

CAUTION! Any manual door closer, including those certified by BHMA to conform to ANSI Standard A156.4, that is selected, installed and adjusted based on ADA or other reduced opening force requirements may not provide sufficient power to reliably close and latch a door.

Refer to POWER OPERATORS section for information on systems that meet reduced opening force requirements without affecting closing power.

* Maximum opening force.

	DOOR WIDTH	36"	42"	48"
	8.5* lbs.	4211	4211	4211
5.0* lbs.	4211	4211	4211	

* Maximum opening force.