



941128-00

672 Series



RX TouchBar Exit Device

Installation Instructions

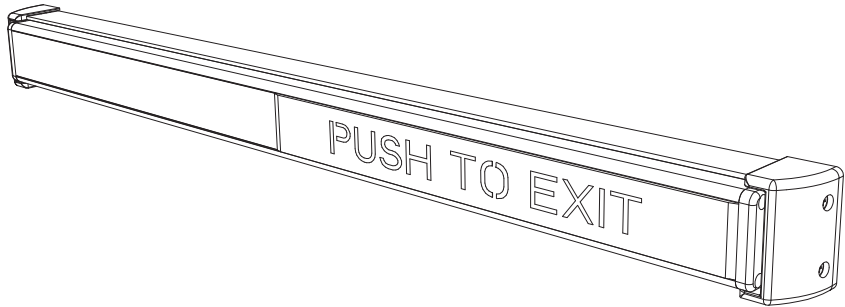
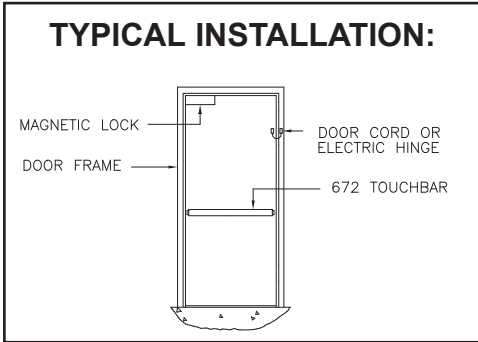

GENERAL DESCRIPTION: The 672 Series Request to Exit TouchBar is a non-latching releasing device. It is most often used as a switch to release a magnetic lock. A double pole output is standard, and allows for use when integrating with a monitoring system which requires a signal for legal egress. The device can be ordered to fit 3 standard door openings or can be cut to size in the field. A 24-inch (minimum) pre-connected cable comes standard to make installation easier.

These devices are to be installed in accordance with the applicable codes and the local authorities having jurisdiction. It is up to local authority having jurisdiction whether this is to be installed in lieu of panic hardware.

WHAT MODEL DO YOU HAVE?

EXAMPLE: 672-36-628-RD-RHR-WD

HANDING:
RHR or LHR (Shown above) to change hand (if required) see page 2.

DOOR WIDTH:
36"
42"
48"

OPTIONS:
AR 18" armored door cord (no wire)
WD Sex nuts/screws for wood or hollow metal door applications
SHK Aluminum door mounting shim kit (screws included)

PUSHPAD:
RD Black Pushpad w/ RED letters
GID Glow-in-dark

BAR FINISHES:
628 Satin aluminum
313 Dark Satin Bronze

STEP 1

Place the TouchBar on the door and measure the distance between each end and the stop (or frame on a blade stop door). It should be at least 3/8" of an inch. If so, proceed to step 2. If not, the TouchBar will need to be cut to size.

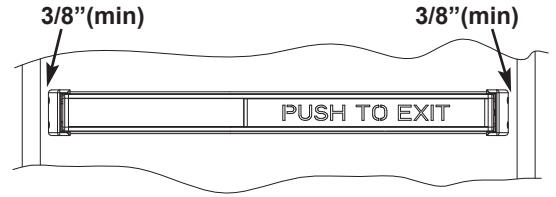

CUTTING TOUCHBAR TO SIZE:

A. Measure the DOOR WIDTH, hereafter referred to as dimension "X"

HOLLOW METAL OR WOOD DOOR:



B. Disassemble the TouchBar as shown below:

1. REMOVE END CAPS AND BRACKETS.
2. REMOVE PIVOT HINGE COMPONENTS AND SWITCH COMPONENTS. KEEP THE PIVOT HINGE AND SWITCH ASSEMBLIES TOGETHER WHEN DISASSEMBLING DEVICE.

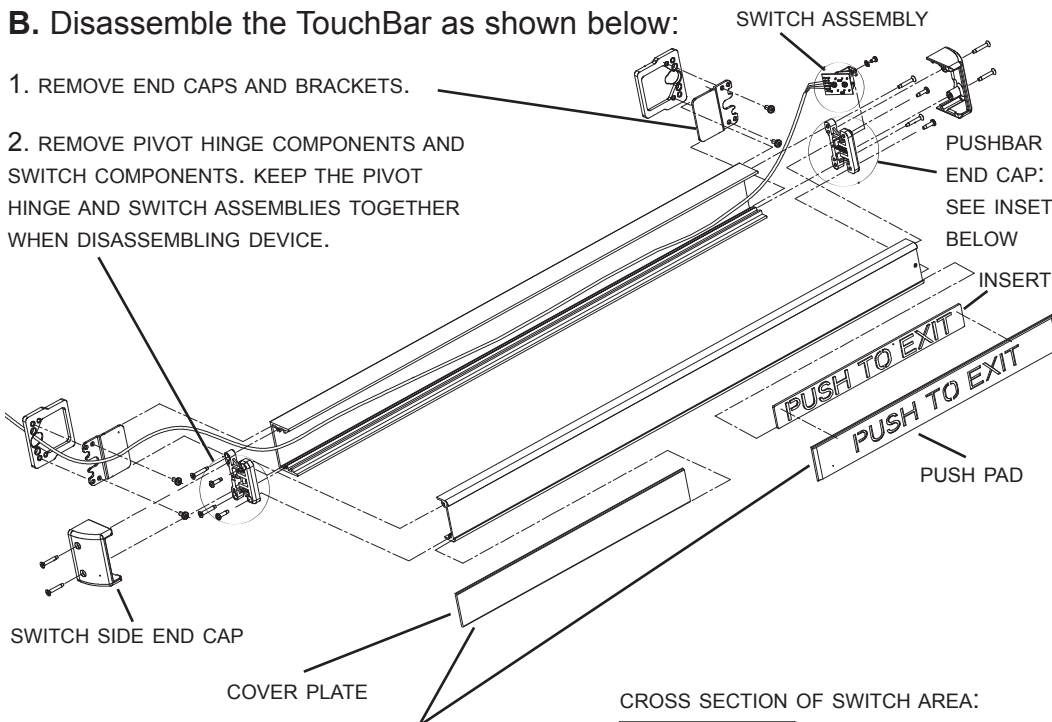

CHANGING HAND:

1. REMOVE SWITCH SIDE END CAP AND PUSHBAR END CAP.
2. REMOVE "PUSH TO EXIT" SIGN AND INSERT AND REVERSE LETTER DIRECTION.
3. REFER TO THIS PAGE TO RE-INSTALL END CAPS.

3. SLIDE OUT PUSH PAD AND EXIT SIGN (IF FURNISHED) AS SHOWN. SLIDE OUT COVER PLATE.

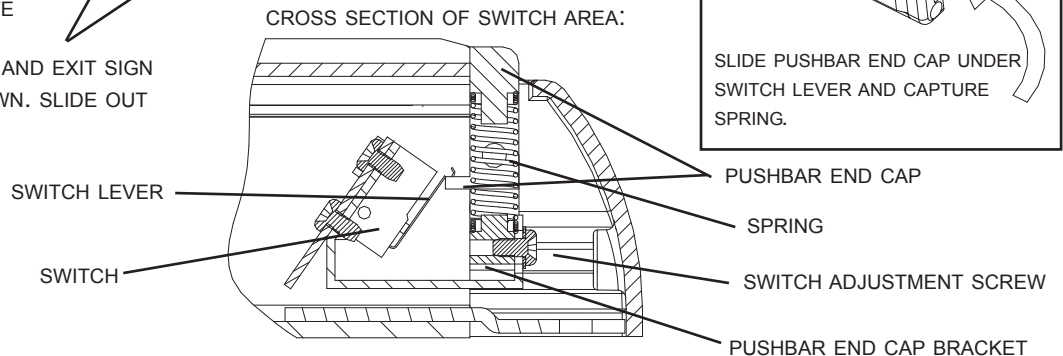
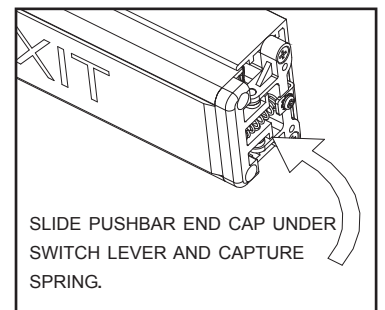

SEE BACK COVER FOR COMPLETE EXPLODED VIEW.

C. Calculate the correct length to cut the housing extrusion and pushbar extrusion using the door width as determined in step 1 (dimension “X”).

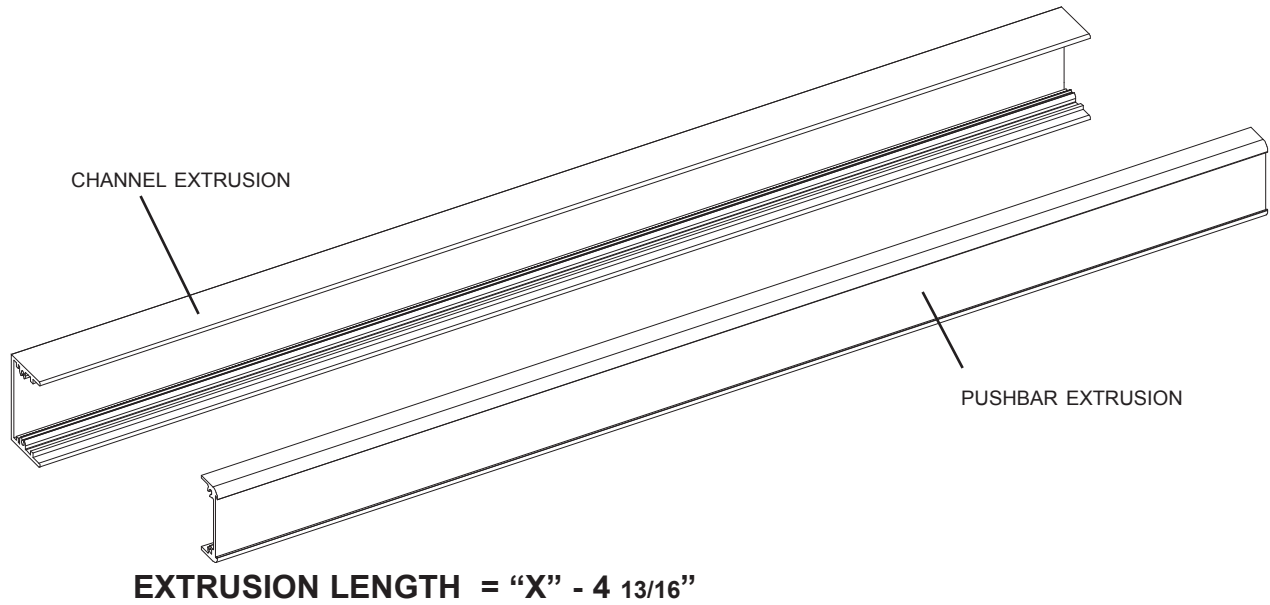

D. Calculate the correct length to cut the cover plate extrusion using the door width determined in step 1.

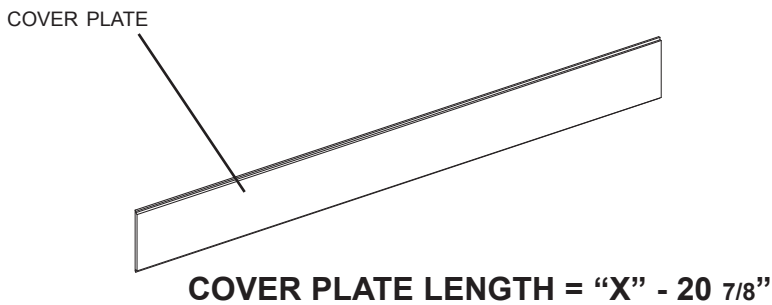

E. Cut metal parts to length determined above (using a metal miter saw is recommended to ensure a good clean cut and a right angle). Do not cut the plastic push pad.

F. Reassemble the TouchBar (without installing the end caps). Note that the screws which connect parts to the aluminum extrusions are self tapping (thread forming) screws. It is recommended that a power tool be used to drive them in. This will make assembly easier.

NOTE: AT THIS TIME THE TOUCHBAR CAN BE HANDED BY ASSEMBLING THE "PUSH TO EXIT" SIGN (IF FURNISHED) IN THE CORRECT ORIENTATION.

STEP 2 LOCATING AND DRILLING THE WIRE HOLE

- a. On the **hinge-side** of door, mark a horizontal centerline at the desired height for the TouchBar.
- b. Place a channel end cap bracket over the centerline.
- c. Center wire hole in the adapter plate with the centerline that was marked on door. (See below)
- d. Mark center of wire hole and center of one mounting hole.
- d. Drill a 5/8" wire access hole at wire hole mark. **DO NOT DRILL WIRE HOLE THRU DOOR.**

WIRE HOLE LOCATION:

Note that hole size and location depends on fastener type (SEE STEP 3).

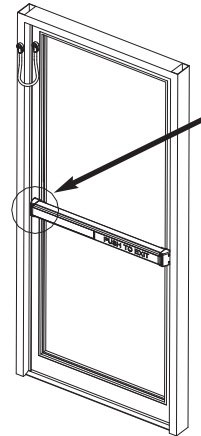
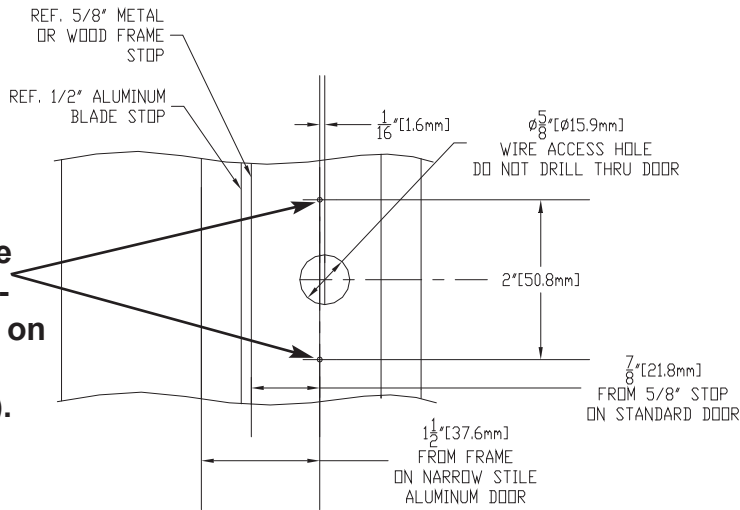

WIRE HOLE IS ALWAYS ON HINGE SIDE OF FRAME

STEP 3 MARK AND DRILL MOUNTING HOLES

Fasten TouchBar to door. There are three methods of fastening the device to the door:

USE A LEVEL WHEN MARKING HOLES

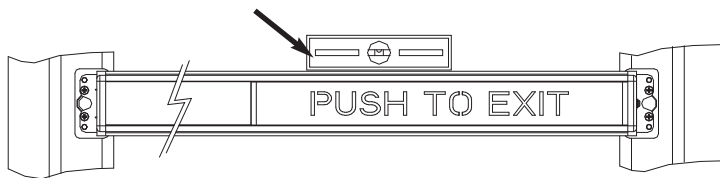

SELF DRILLING SELF TAPPING SCREWS:

- a. Hold device in position determined in step 2.
- b. Using a powered screw driver, screw in one screw on one side.
- c. Level the device. Secure other side with self drilling screw.
- d. Install remaining two screws.

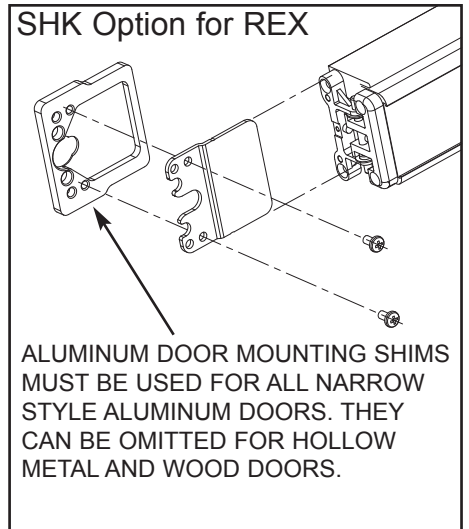

BLIND NUT INSTALLATION:

- a. Drill four 9/32” holes *on device side only* of door in positions marked in step 3.
- b. Install blind nuts as shown to right.
- c. Secure device using # socket cap screws.

I. Assemble tool to install blind nut as shown using the parts supplied.

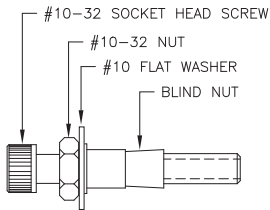

II. Install blind nut assembly into pre-drilled 9/32” hole in door. Hold the socket head screw firmly with the hex wrench to prevent rotations as shown.

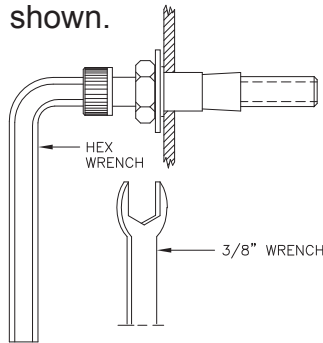

III. Using a 3/8” wrench, rotate the nut clockwise until the nut collapses against the inside of the door skin. Some resistance will be felt. **Carefully tighten until nut is secure. Do not overtighten.**

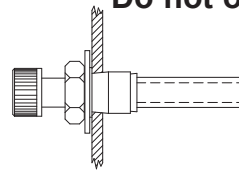

WD OPTION - SEX NUTS FOR WOOD DOORS:

- a. Drill four 13/32” holes thru door in positions marked in step 3.
- b. Using a rubber mallet, hammer in sex nuts from opposite side of door.
- c. Secure device using #10-24 pan head screws.

STEP 3: WIRING

Provision must be made for conductors to get to the device on the door. Common methods are an electric hinge, door cord, or power transfer device. Purchase with AR option to receive a model 798-18 armored door cord to facilitate power transfer. Make wiring connections as required by the system wiring diagram. Contact colors are shown below:

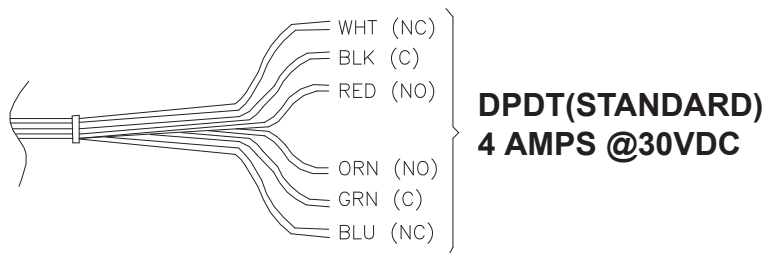

SWITCH ADJUSTMENT:

The switch sensitivity is set at the factory. If the switch is determined to be too sensitive or not sensitive enough it can be adjusted by loosening the screw which secures the switch assembly and sliding the switch to the left or right. **BE SURE TO TIGHTEN THE SCREW AFTER ADJUSTMENT.**

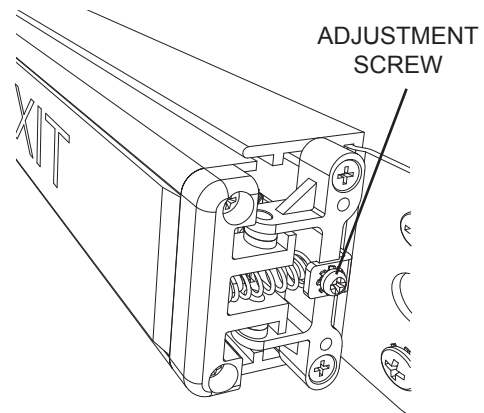

PARTS BREAKDOWN

