

FRAME PREPARATION (LHRB APPLICATION SHOWN)

Drawing shows only one method of installation. Method of installation may vary per door and frame manufacturer.

Back box provided by hollow metal manufacturer to keep dust and dirt out of strike pocket. Construct the box in a manner that will hold it's shape. Minimum material thickness 16 gauge.

Conduit holes to be added as required to hold wire connections

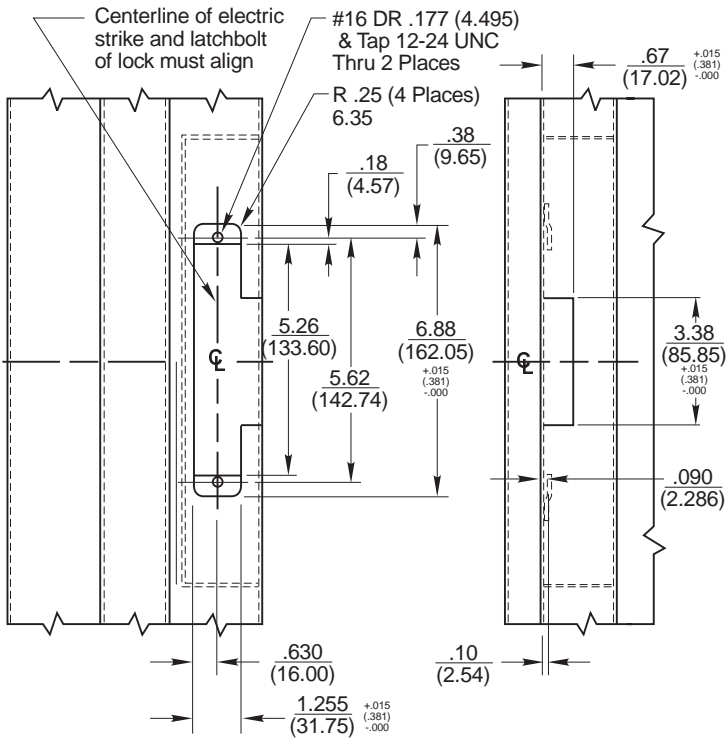
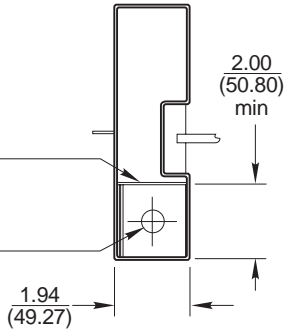

MODEL 205 ELECTRIC STRIKE

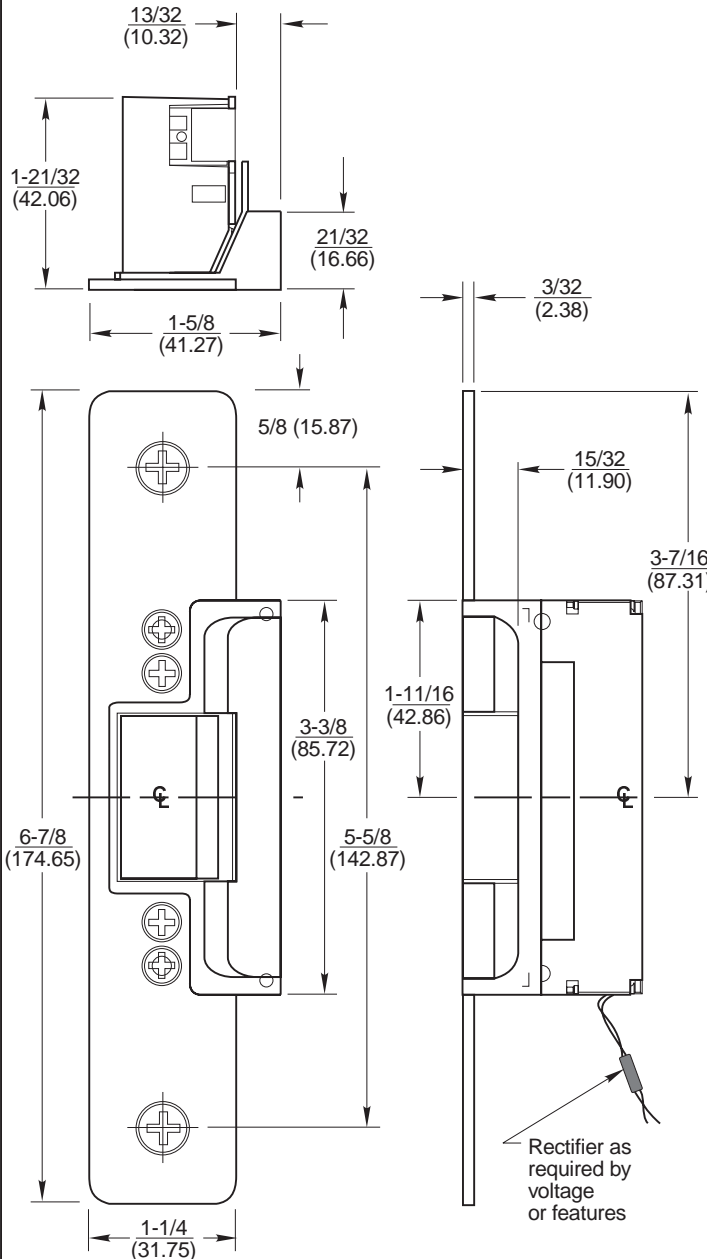

NOTES:

1. DO NOT SCALE - All dimensions in inches (mm).
2. Dimensions subject to change without notice.
3. Number of wires will vary per features of strike.
4. Cut off all excess wire not required for installation.
5. Wires to be run from side of strike to conduit connection.
6. All wiring connections to be made opposite the solenoid end of strike. If a rectifier (optional) is used, it may be installed at either end of strike.
7. Refer to catalog for available finishes, voltages, and optional features.
8. Door & frame manufacturers are responsible for providing adequate construction or reinforcements for proper installation of hardware.
9. Tolerances shown are for cutouts.
10. Remove all burrs and break sharp edges.

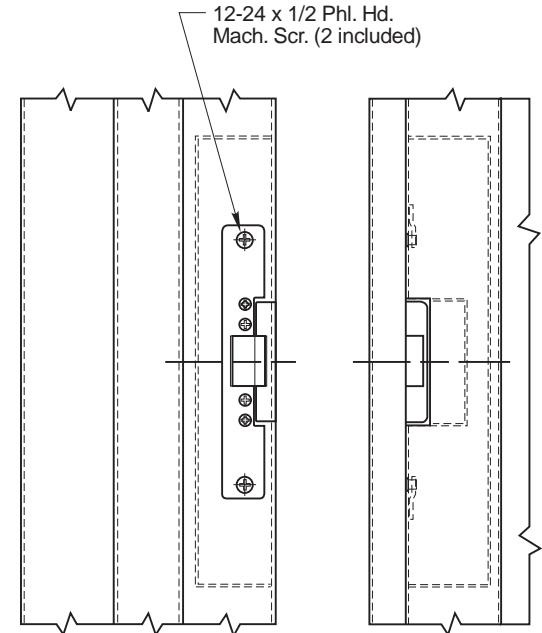

205 Electric Strike Mounting For Aluminum (Long)



REF. REPAIR PART DWG.

P.O. BOX 25288, CHARLOTTE, NC 28229-8010

TEMPLATE NUMBER

092-0252-003

DATE

9-98