

INSTALLATION DESCRIPTION

The Model 2282-TJ82 is a top jamb mounted electromagnetic lock designed to secure a pair of inswinging doors, with 1200 pounds holding force per leaf. The lock requires installation procedures as described herein and in the separate wiring instructions.

Typical installation of the lock on a double inswinging door:

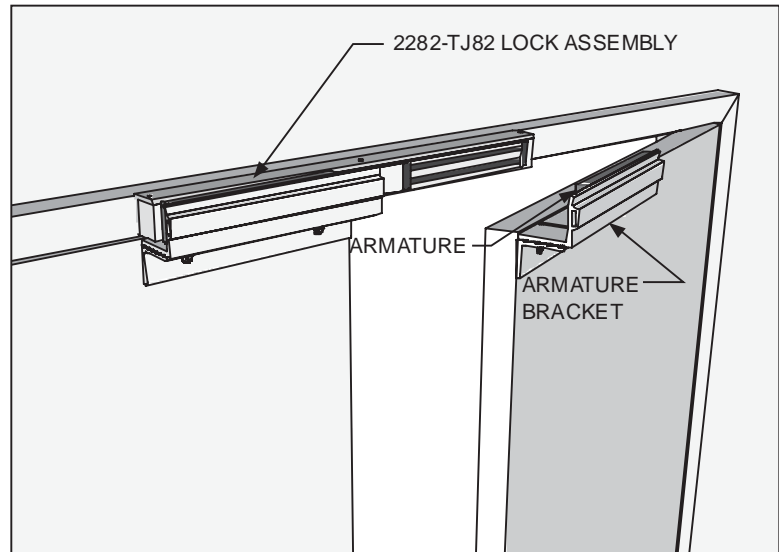

HANDLING

Care must be taken that the lock and armature faces are kept free of dirt, rust, paint, or any other obstruction which may interfere with the lock and armatures making good contact. These faces may be cleaned with a non-abrasive pad and wiped with an oil dampened cloth.

MECHANICAL INSTALLATION

Familiarize yourself with the door and frame conditions. The lock must mount rigidly to the face of the door frame header. The door mounted armatures are supplied with hardware that allows them to pivot slightly to compensate for reasonable misalignment.

NOTE: If this lock is supplied with the DSM2 option be certain that magnets are present inside the armature housings.

ELECTRICAL INSTALLATION

After mechanical installation is complete the lock needs to be wired to a 12 or 24 VDC/VAC power source. Once low voltage power is supplied the unit is fully operational. All other wiring is for selected options. Refer to the separate wiring instructions included for further information.

TABLE OF CONTENTS

General Information.....	1
Bill Of Materials.....	2
Mounting Considerations.....	3
Install Lock Mounting Bracket.....	3
Assemble Armature Mtg. Bracket.....	4
Install Armature Mtg. Bracket.....	5
Armature Mtg. Bracket Adjustment.....	6
Exploded Parts View.....	7
Exploded Parts Legend.....	8
Support.....	8

MODEL #2282-TJ82 BILL OF MATERIALS

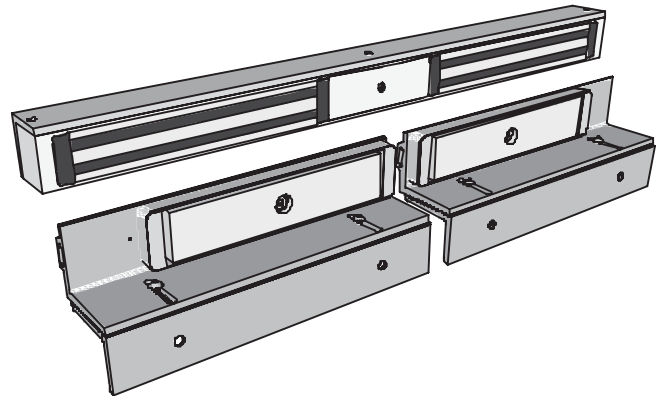

- (1) 2282-TJ82 LOCK ASSEMBLY
- (2) ARMATURE
- (2) ARMATURE HOUSING
- (2) ARMATURE MTG BRACKET SET
- (2) HARDWARE KIT
- (1) MOUNTING TEMPLATE DRAWING
- (1) INSTALLATION MANUAL
- (1) WIRING MANUAL

REQUIRED TOOLS

- (1) Electric Drill
- (1) #2 Phillips Screw Driver
- (1) Soft Faced Mallet
- (1) Hammer
- (1) Center Punch
- (1) Pencil & Tape

Drill Bits: 1/8", 17/64", 11/32", 1/2", 9/16", 21/32"

HARDWARE KIT CONTENTS (P/N 301307 x 2)

QTY.	DESCRIPTION
8	#10x1" sheet metal screw
8	#10-24x1/2" machine screw
4	5/16-18x1-3/4" TJ bracket bolt
8	8-32x3/8" machine screw
2	3/8"Dx0.360"L spacer
2	1/4" flat steel washer
4	5/8"Dx1-11/16"L spacer
4	5/16-18 sex nut

QTY.	DESCRIPTION
2	5/16-18x3/4" armature bolt, turned
4	1/4-20x1/2" button head screw
4	lock washer
3	anti-tamper plug
1	5/32 hex wrench
1	3/16 hex wrench

NOTE: For further parts clarification refer to the Exploded Parts View on page 7 or consult factory.

MOUNTING CONSIDERATIONS

1. Individual door and frame conditions may vary. Dimensions shown at right are for a typical hollow metal door and frame.
2. The Lock Assembly should be mounted in the center of the frame. Verify that there is proper clearance for the lock assembly at the planned mounting location.

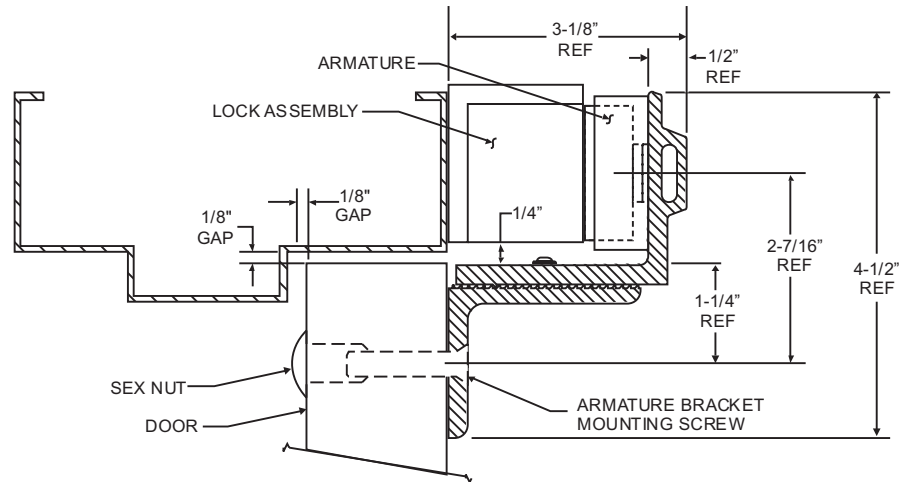

INSTALL THE LOCK MOUNTING BRACKET

1. Separate the Lock Mounting Bracket from the Lock Assembly (see page 6). Standing at the "pull" side of the door, place the Lock Mounting Bracket on the face of the frame header as shown below. Using the Template Drawing, locate and mark the centers of the two slotted mounting holes and the wiring hole.
2. Drill the marked holes in the face of the frame header:
 - a. two 1/8" holes for #10x1" sheet metal screws or drill and tap for 10-24x1/2" machine screws
 - b. one 5/8" hole for wiring
3. Attach the Lock Mounting Bracket to the frame header. Tighten the screws just enough to allow for final adjustment.

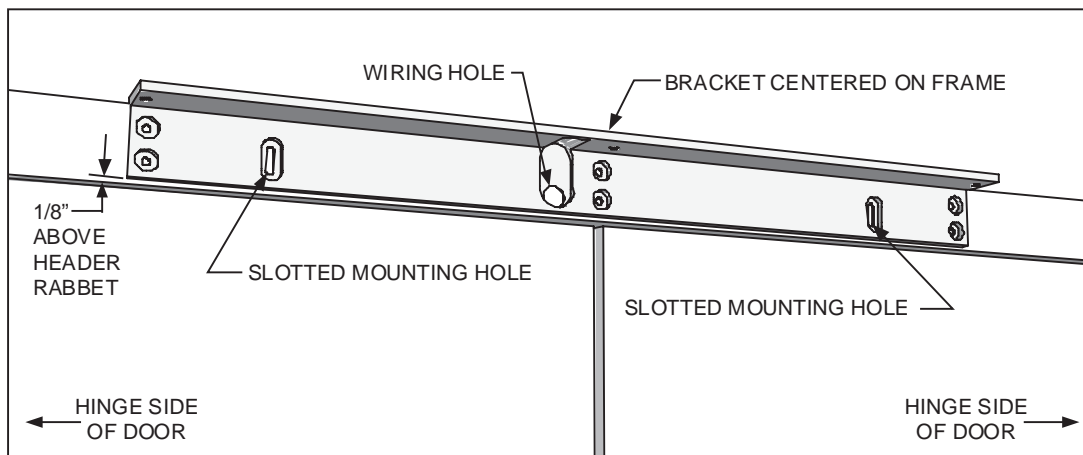
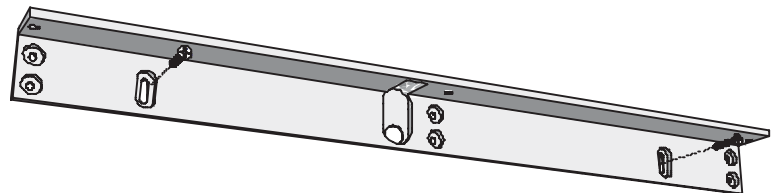

ASSEMBLE THE ARMATURE MOUNTING BRACKETS

Locate two 1/4-20x1/2" armature mounting bracket assembly screws and lock washers from the hardware kit and assemble the bracket as shown.

Firmly tighten the mounting screws with a 5/32" hex wrench. They may be loosened later for adjustment, as necessary.

Repeat for second bracket.

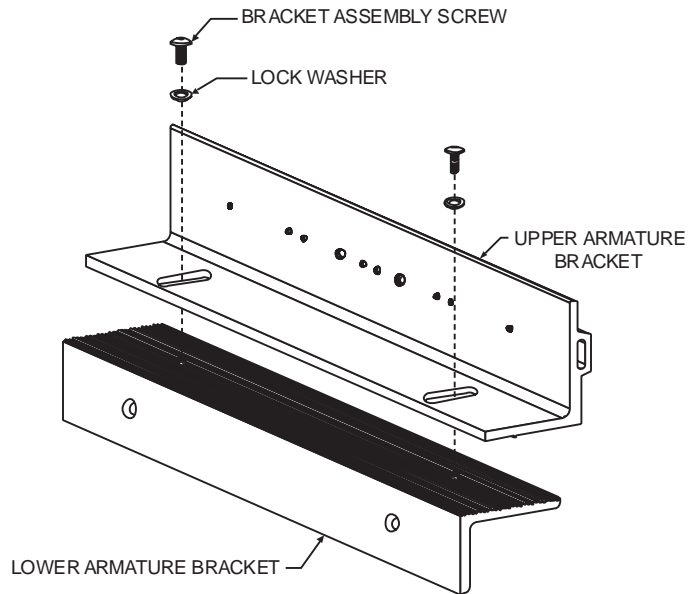

ATTACH THE ARMATURES TO THE ARMATURE MOUNTING BRACKETS

Attach the Armature Housing to the top Armature Mounting Bracket using four (4) 8-32x3/8" Armature Housing Screws. Attach the armature to the armature mounting bracket as shown. Firmly tighten the Armature Mounting Screw using a 3/16" hex wrench.

Repeat for second bracket.

Failure to properly secure the armature to the bracket could result in serious injury or possible security breach.

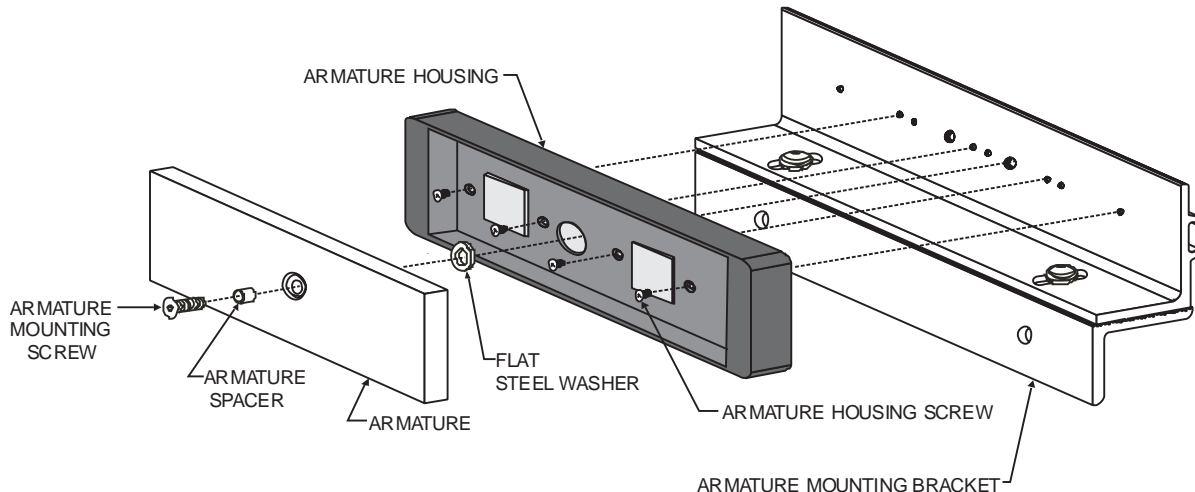

INSTALL THE ARMATURE MOUNTING BRACKETS

1. Use the figures below to identify and mark the locations of the armature mounting bracket screw holes on the door.

Refer to Template Drawing #301341 for further information.

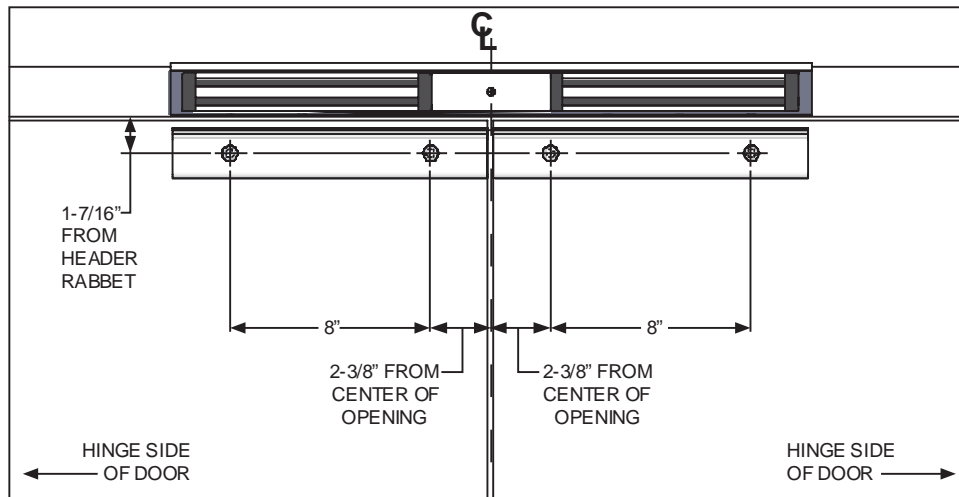

2. From the illustrations below select the one that resembles your door type and follow the instructions for drilling the four (4) armature mounting bracket screw holes.

GLASS & ALUMINUM OR HOLLOW METAL DOOR

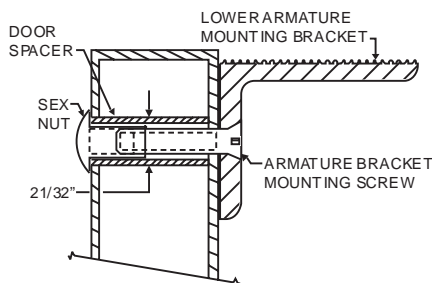

Drill an 11/32" diameter hole through door. From sex nut side only enlarge the 11/32" hole to 2 1/32" diameter.

SOLID CORE DOOR

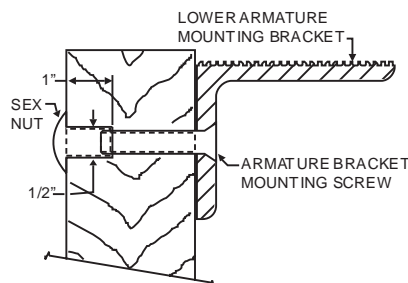

Drill an 11/32" diameter hole through door. From sex nut side only drill 1/2" diameter hole to 1" depth.

REINFORCED DOOR

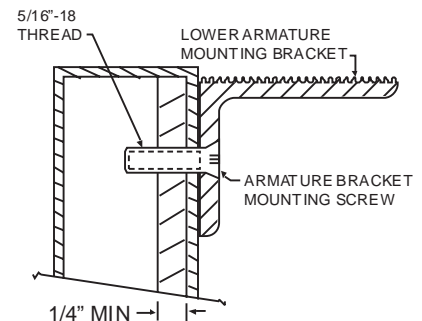

Drill an 17/64" diameter hole and tap for 5/16"-18 thread.

3. Mount the armature and mounting bracket assemblies to the doors using the appropriate hardware for your door type. Firmly tighten the mounting screws with a 3/16" hex wrench.
4. Temporarily mount the Lock Assembly to the Lock Mounting Bracket using (3) 1/4-20 x 1-1/4" socket head screws.

ARMATURE ADJUSTMENT

- Using a 5/32" hex wrench, temporarily loosen the armature bracket assembly screws roughly 1-1/2 turns to allow the upper armature bracket to move in and out freely (Ref. Figure "A").
- Close and latch the door. The mating surfaces of the lock and armature should fully contact each other. If necessary, slide the armature in or out to ensure full contact is made with the lock while still allowing the door to properly close and latch. Move the lock assembly up or down to achieve proper vertical alignment.
- When the desired adjustment is achieved, slowly open the door taking care to maintain the position of the armature. Firmly tighten the armature bracket assembly screws, making sure that the locking ribs on the upper and lower bracket halves properly mesh (Ref. Figure "A").
- Dismount the lock assembly from the lock mounting bracket and tighten the two slot mounting screws. Using the bracket as a template, drill and install the six remaining bracket mounting screws. Mount the lock and install the two aluminum anti-tamper plugs using a soft faced mallet.

NOTE:

Make sure the door hits the frame just before the armature hits the maglock, to prevent loosening over time (armature not slamming against the lock).

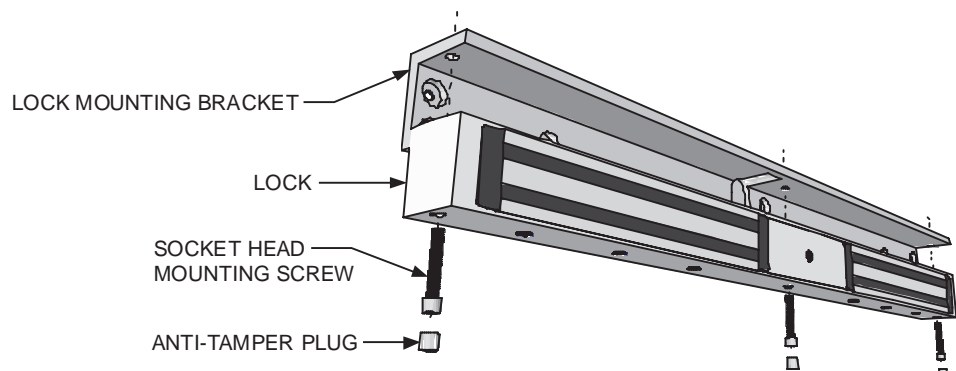
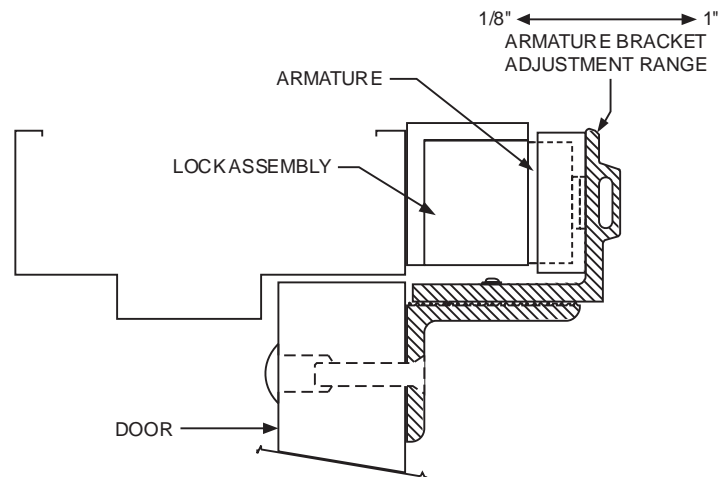
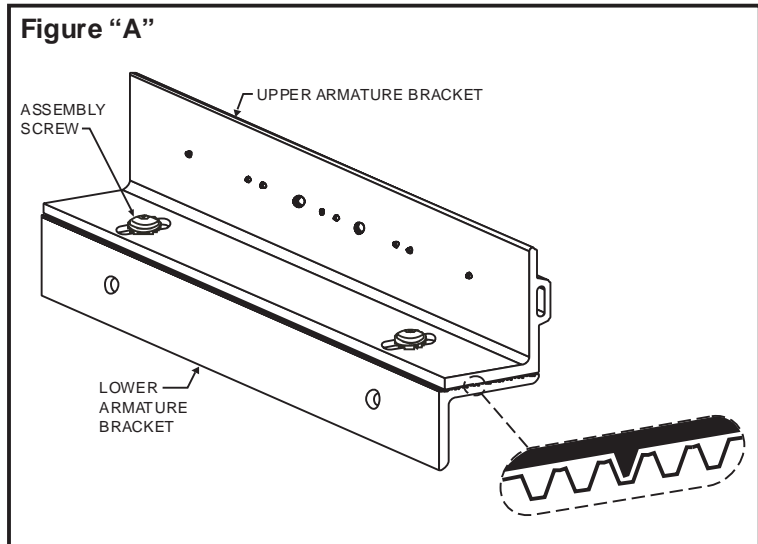

EXPLODED PARTS VIEW

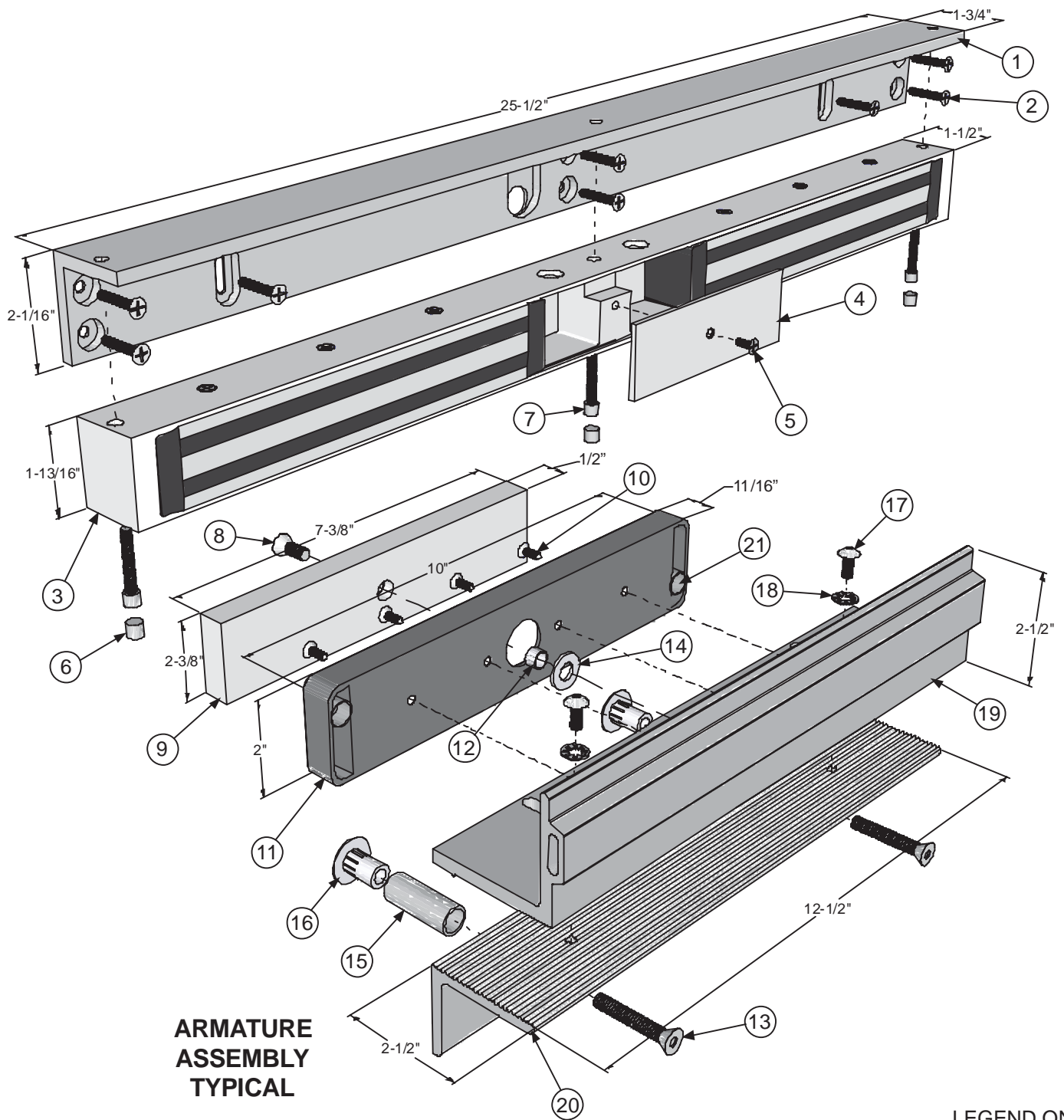

**ARMATURE
 ASSEMBLY
 TYPICAL**

LEGEND ON
 NEXT PAGE





705 Emmett Street • Bristol, CT 06010
1-877-DynaLock • www.dynalock.com

**MODEL 2282-TJ82 DOUBLE/INSWING
ELECTROMAGNETIC LOCK
INSTALLATION INSTRUCTIONS**

PARTS LEGEND

ITEM	DESCRIPTION	PART #
1	Lock Mounting Bracket	301271
2	#10x1" Self-Tapping Screw	*
2	10-24x1/2" Machine Screw	*
3	Lock Housing	301299
4	Access Cover	301298
5	8-32x3/8" Machine Screw	300608
6	Anti-Tamper Plug	*
7	1/4-20x1-1/4" Socket Head Screw	300603
8	5/16-18x3/4" Arm. Screw, Turned	*
9	Armature	300968

ITEM	DESCRIPTION	PART #
10	8-32x3/8" Machine Screw	*
11	Armature Housing	301245
12	0.360"L Armature Spacer	*
13	5/16-18x1-3/4" TJ Bracket Bolt	*
14	Steel Washer	*
15	Door Spacer Tube	*
16	Sex Nut	*
17	1/4-20x1/2" Button Head Screw	*
18	Lock Washer	*
19	Top Armature Mounting Bracket	301262
20	Bottom Armature Mtg. Bracket	301274
21	Disc Magnet (DSM only)	301289

Refer to Page 7 for parts locations.

* Part of Hardware Kit (301307 x 2)

**PLEASE DELIVER THIS MANUAL
TO THE END-USER UPON COMPLETION
OF THE INSTALLATION**

THE FOLLOWING LISTINGS ARE PENDING



**NYC Mea #23-92-E
GWXT Auxiliary Lock**

**FOR PRODUCT SUPPORT AND PARTS
ORDERING INFORMATION CONTACT:**

DynaLock Corp.
705 Emmett Street
Bristol, CT 06010
Bus: (877) DYNALOCK, Toll-Free USA
(860) 582-4761
Fax: (860) 585-0338

DYNALOCK ON THE INTERNET:

E-mail: info@dynalock.com
Website: www.dynalock.com