

### READ THIS FIRST!

These supplemental instructions supersede all references to the armature and armature mounting brackets in the 2000TJ Series installation manuals. Armatures now utilize a plastic housing which may contain magnets for use with the Door Status Monitor option, and the rubber washer has been eliminated from the hardware pack.

### ASSEMBLE THE ARMATURE MOUNTING BRACKET

Locate the two armature mounting bracket assembly screws and lock washers from the hardware kit and assemble the bracket as shown.

Firmly tighten the mounting screws with a 5/32" hex wrench. They may be loosened later for adjustment, to insure that the armature makes good contact with the magnet face.

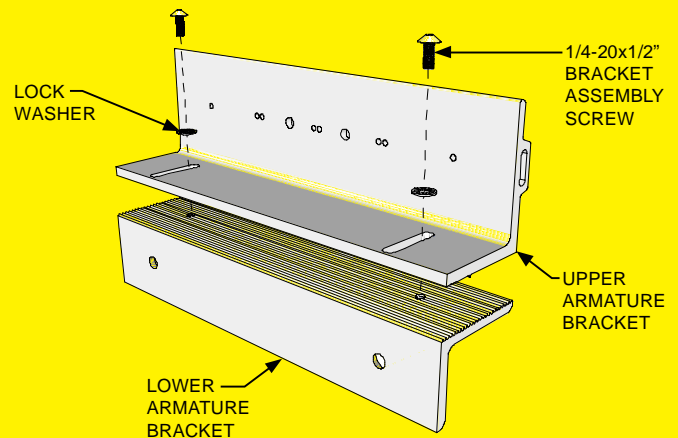

### ATTACH THE ARMATURE TO THE ARMATURE MOUNTING BRACKET

Attach the armature housing to the top armature mounting bracket using four (4) 8-32x3/8" armature housing screws. Attach the armature to the armature mounting bracket as shown. Firmly tighten the armature mounting screw using a 3/16" hex wrench. Install as shown for LH single locks. For RH installations use the alternate mounting holes. Double lock installations will utilize both sets of holes, one for each leaf.

**Failure to properly secure the armature to the bracket could result in serious injury or possible security breach.**

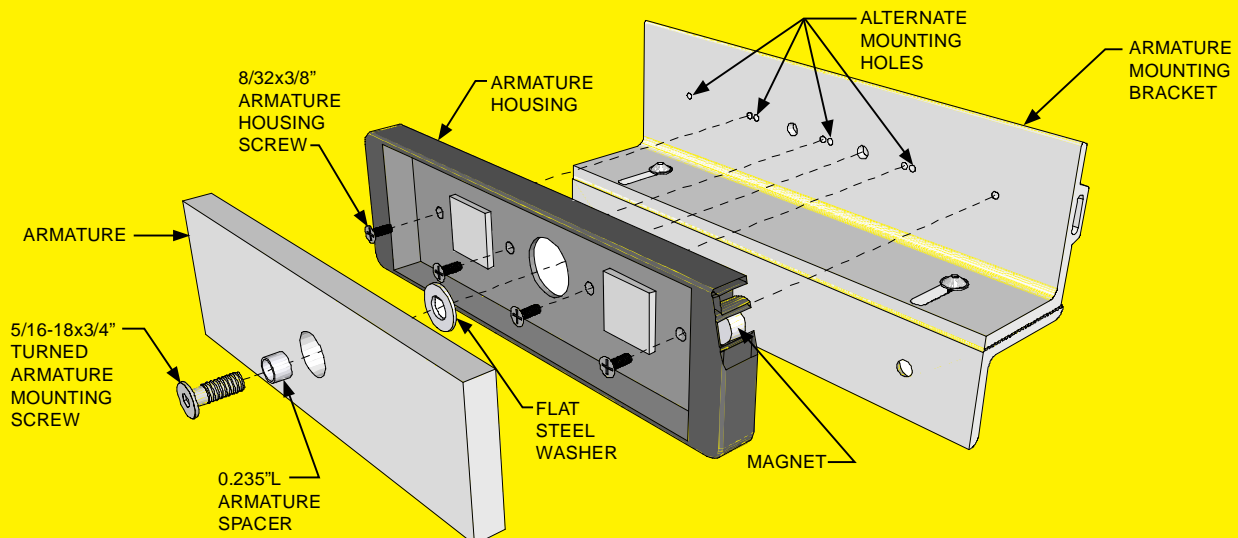

**NOTE:** For locks ordered with the DSM or HSM option, please verify that two magnets are installed inside the armature housing.