

330 and 430 Exit Alarms

330 and 430 Specifications

- Chassis and cover made from a non-ferrous alloy, 12-3/4" x 2" x 2-5/8".
- 9 volt battery powered. Modern, solid state electronics.
- 3/4" latchbolt monitored by an electronic sensor switch.
- For out swinging doors 1-3/4" thick with 4" minimum stile.
- Inside cylinder operation to arm or disarm unit using a 1-1/8" mortise cylinder. (Order cylinder separately).
- Reversible. Unit is packed RHRB.
- Powder coated painted finishes: AL, BRZ, RD.
- Hardware finishes: US10, US10B, US26, US26D.
- Auto relatching.
- Red LED indicator flashes when violation occurs. Light continues to flash beyond alarm cycle and can only be turned off by the inside key.
- Units set up to accept outside cylinder operation as standard.
- One chassis will accept all available trim options.
- Unit must be activated to test available battery power. Low battery alert feature causes unit to chirp intermittently to indicate low battery power.
- Available with AR, RM, CA and RP options. See below for option descriptions:

AR—Auto-Rearming	RM—Remote Monitor
CA—Continuous Alarm	RP—Remote Power

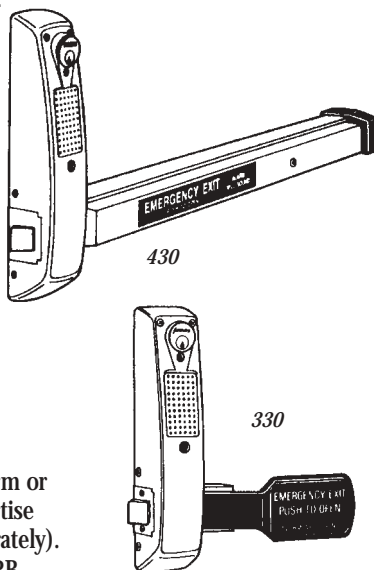

330 Features

- Paddle made from a non-ferrous alloy.
- Paddle projection 3-1/4"; length to end of paddle 10-3/8".
- 90 decibel alarm sounds for 2 minutes, shuts off and automatically rearms itself. Piercing, dual frequency pulsating horns.
- UL listed. Designed to meet ANSI 156.5-1984 and A117.1-1980 for Accessibility Standards.

430 Features

- Rolled steel touchbar assembly to fit 30" to 36" door furnished standard. Bars to fit 24" to 30" and 37" to 48" available. Can be cut to size in the field.
- Piercing, dual frequency pulsating horns. Rated for 90 decibels at 6 feet. (Alarm sounds for two minutes then shuts down and re-arms automatically. A 15 second delay upon alarming allows authorized egress without sounding alarm.)
- UL listed for exit hardware. Also available UL rated for fire exit hardware (Prefix "F" to model number). Designed to meet ANSI 156.3-1984 and A117.1-1980 for Accessibility Standards.

100 Series Exit Alarm

- Non-ferrous alloy cover and base, 8-3/8" x 2" x 2-5/8". Tamper-proof cover.
- 9 volt battery powered.
- Magnet activated.
- For inward or outward swinging doors with 4" minimum stile.
- Non-handed.
- 90 decibel alarm sounds for 2 minutes, shuts off and automatically rearms itself. Piercing, high frequency horn.
- Inside cylinder operation to arm or disarm unit using 1-1/8" mortise cylinder. Outside rim cylinder operation standard. (Order cylinders separately).
- Powder coated painted finishes: AL BRZ, RD.
- Hardware finishes—US10, US10B, US26, US26D.
- Available option—AR.

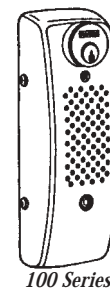

110 Series

Push button test to determine available battery power.

130 Series

15 second delay upon arming permits key holder to exit door without sounding alarm. Intermittent chirp indicates low battery power. LED indicator flashes beyond alarm, reset by inside key.

Exit Alarm Options

Automatic Rearming

- Units are provided with spring loaded on/off switch. Switch automatically returns to the on position after removal of key.
- Alarm can never be left off.
- Available for all alarm models.
- To order—specify prefix AR.

Remote Monitor

- Alarm supplied with 8 foot wire leads attached to electronics assembly, allowing remote monitoring.
- Can be used in conjunction with Arrow S40 remote panel or with panel light or bell provided by other manufacturers.
- Closed loop circuitry provides highest security.
- To order—specify prefix RM (not available for Model 110).

Continuous Alarm

- Horns will sound continuously after a violation has occurred—does not shut off after 2 minute alarm cycle.
- Only disarming by key operation will quiet the alarm.
- Remote power is recommended for units with this feature.
- To order—specify prefix CA (not available for Model 110).

Remote Power

- Alarm supplied with 6 foot wire leads attached to electronics assembly, powering unit from external source.
- Can be used in conjunction with Arrow S63 Hard Wired Battery Eliminator or other remote 9V power source.
- To order—specify prefix RP (not available for Model 110).